



80% 2-STAGE VARIABLE SPEED GAS FURNACE INSTALLATION INSTRUCTIONS

ATTENTION INSTALLATION PERSONNEL

As a professional installer, you have an obligation to know the product better than the customer. This includes all safety precautions and related items. Prior to actual installation, thoroughly familiarize yourself with this instruction manual. Pay special attention to all safety warnings. Often during installation or repair, it is possible to place yourself in a position which is more hazardous than when the unit is in operations.

Remember, it is your responsibility to install the product safely and to know it well enough to be able to instruct a customer in its safe use. Safety is a matter of common sense...a matter of thinking before acting. Most dealers have a list of specific good safety practices...follow them.

The precautions listed in this installation manual are intended as supplemental to existing practices. However, if there is a direct conflict between existing practices and the content of this manual, the precautions listed here take precedence.



Keep this literature in a safe place for future reference.

These furnaces comply with requirements embodied in the American National Standard/National Standard of Canada ANSI Z21.47-CSA-2.3 Gas Fired Central Furnaces.

Whirlpool Gold® Models
WGFD295, WGFM295
WPIO-369C

Tradewinds Distributing Company, LLC
14610 Breakers Drive
Jacksonville, Florida 32258



TABLE OF CONTENTS

GAS FURNACE SAFETY PRECAUTIONS	3	Gas Supply Pressure Measurement	22
Additional Safety Considerations.....	4	Gas Manifold Pressure Measurement and Adjustment.....	23
PRODUCT DESCRIPTION AND APPLICATION	4	Gas Input Rate Measurement—Natural Gas Only.....	24
Shipping Inspection	4	Temperature Rise	24
Electrostatic Discharge (ESD) Precautions.....	4	Circulator Blower Speeds	25
To the Installer.....	4	Blower Heat Off Delay Timings	27
Important Note to the Owner Regarding Product Warranty	5	NORMAL SEQUENCE OF OPERATION	27
Product Application.....	5	Power Up.....	27
LOCATION REQUIREMENTS AND CONSIDERATIONS	6	Heating Mode.....	27
Clearances and Accessibility	7	Cooling Mode.....	28
Furnace Suspension	7	Fan Only Mode.....	28
Existing Furnace Removal	8	Operational Checks.....	28
Thermostat Location	8	SAFETY CIRCUIT DESCRIPTION	28
COMBUSTION AND VENTILATION AIR REQUIREMENTS	8	General	28
Category I Venting—Vertical Venting.....	8	Integrated Control Module	28
Category I Furnaces Only—Exterior Masonry Chimneys.....	9	Primary Limit Control.....	29
ELECTRICAL CONNECTIONS	13	Auxiliary Limit Controls.....	29
Wiring Harness.....	13	Rollout Limit Controls.....	29
115-Volt Line Connections.....	13	Pressure Switches.....	29
Junction Box Relocation.....	14	Flame Sensor.....	29
24-Volt Thermostat Wiring	14	MAINTENANCE	29
24-Volt Dehumidistat Wiring	16	Annual Inspection.....	29
Fossil Fuel Applications	16	Filters	29
115-Volt Line Connection of Accessories		Burners	30
(Humidifier and Electronic Air Cleaner)	16	Induced Draft and Circulator Blowers.....	30
GAS SUPPLY AND PIPING	17	Condensate Trap and Drain System (Qualified Servicer Only).....	30
High Altitude Derate	17	Flame Sensor (Qualified Servicer Only).....	30
Propane Gas Conversion.....	17	Flue Passages (Qualified Servicer Only)	30
Gas Piping Connections	18	Before Leaving an Installation	30
Gas Piping Checks.....	19	Repair and Replacement Parts	30
Propane Gas Tanks and Piping	19	TROUBLESHOOTING	31
CIRCULATING AIR AND FILTERS	21	Electrostatic Discharge (ESD) Precautions.....	31
Ductwork—Airflow	21	Fault Recall	31
Filters—Read this Section Before		Resetting from Lockout.....	31
Installing the Return Air Ductwork	21	Status Codes.....	31
START-UP PROCEDURE AND ADJUSTMENT	22	Diagnostic Chart.....	32
Heat Anticipator Setting.....	22	DIP Switch Chart	38
Furnace Operation	22	WIRING DIAGRAM	39
Furnace Start-Up	22	ASSISTANCE OR SERVICE	40
Furnace Shutdown.....	22		

GAS FURNACE SAFETY PRECAUTIONS

Please adhere to the following warnings and cautions when installing, adjusting, altering, servicing or operating the furnace. To ensure proper installation and operation, thoroughly read this manual for specifics pertaining to the installation and application of this product.



Recognize this symbol as a safety precaution.

WARNING

Hazards or unsafe practices could result in property damage, product damage, severe personal injury or death.

CAUTION

Hazards or unsafe practices may result in property damage, product damage, personal injury or death.

WARNING

The manufacturer will not be responsible for any injury or property damage arising from improper service or service procedures. If you install or perform service on this unit, you assume responsibility for any personal injury or property damage which may result. Many jurisdictions require a license to install or service heating and air conditioning equipment.

WARNING

To prevent personal injury or death due to improper installation, adjustment, alteration, service or maintenance, refer to this manual. For additional assistance or information, consult a qualified installer, service agency or the gas supplier.

WARNING

If the information in these instructions is not followed exactly, a fire or explosion may result causing property damage, personal injury or loss of life.

— Do not store or use gasoline or other flammable vapors and liquids in the vicinity of this or any other appliance.

— WHAT TO DO IF YOU SMELL GAS

- Do not try to light any appliance.
- Do not touch any electrical switch; do not use any phone in your building.
- Immediately call your gas supplier from a neighbor's phone. Follow the gas supplier's instructions.
- If you cannot reach your gas supplier, call the fire department.

— Installation and service must be performed by a qualified installer, service agency or the gas supplier.

WARNING

This product contains or produces a chemical or chemicals which may cause serious illness or death and which are known to the State of California to cause cancer, birth defects or other reproductive harm.

WARNING

Heating unit should not be utilized without reasonable, routine inspection, maintenance and supervision. If the building in which any such device is located will be vacant, care should be taken that such device is routinely inspected, maintained and monitored. In the event that the building may be exposed to freezing temperatures and will be vacant, all water-bearing pipes should be drained, the building should be properly winterized and the water source closed. In the event that the building may be exposed to freezing temperatures and will be vacant, any hydronic coil units should be drained as well, and, in such case, alternative heat sources should be utilized.

DANGER



CARBON MONOXIDE POISONING HAZARD

Special Warning for Installation of Furnace or Air Handling Units in Enclosed Areas such as Garages, Utility Rooms or Parking Areas.

Carbon monoxide producing devices (such as an automobile, space heater, gas water heater, etc.) should not be operated in enclosed areas such as unventilated garages, utility rooms or parking areas because of the danger of carbon monoxide (CO) poisoning resulting from the exhaust emissions. If a furnace or air handler is installed in an enclosed area such as a garage, utility room or parking area and a carbon monoxide producing device is operated therein, there must be adequate, direct outside ventilation.

This ventilation is necessary to avoid the danger of CO poisoning which can occur if a carbon monoxide producing device continues to operate in the enclosed area. Carbon monoxide emissions can be (re)circulated throughout the structure if the furnace or air handler is operating in any mode.

CO can cause serious illness including permanent brain damage or death.

WARNING

To prevent possible property damage, personal injury or death due to electrical shock, the furnace must be located to protect the electrical components from water.

WARNING

Should overheating occur or the gas supply fail to shut off, turn off the manual gas shutoff valve external to the furnace before turning off the electrical supply.

WARNING

Possible property damage, personal injury or death due to fire, explosion, smoke, soot, condensation, electrical shock or carbon monoxide may result from improper installation, repair, operation or maintenance of this product.

WARNING

This unit must not be used as a “construction heater” during the finishing phases of construction on a new structure. This type of use may result in premature failure of the unit due to extremely low return air temperatures and exposure to corrosive or very dirty atmospheres.

WARNING

To prevent possible personal injury or death due to asphyxiation, this furnace must be Category I vented. Do not vent using Category III venting. Provisions must be made for venting combustion products outdoors through a proper venting system. The length of flue pipe could be a limiting factor in locating the furnace.

Additional Safety Considerations

- This furnace is approved for Category I venting only.
- Provisions must be made for venting combustion products outdoors through a proper venting system. The length of flue pipe could be a limiting factor in locating the furnace.

PRODUCT DESCRIPTION AND APPLICATION

Shipping Inspection

All units are securely packed in shipping containers tested according to International Safe Transit Association specifications. The carton must be checked upon arrival for external damage. If damage is found, a request for inspection by carrier’s agent must be made in writing immediately.

The furnace must be carefully inspected on arrival for damage and bolts or screws which may have come loose in transit. In the event of damage, the consignee should:

1. Make a notation on the delivery receipt of any visible damage to the shipment or container.
2. Notify the carrier promptly and request an inspection.
3. With concealed damage, the carrier must be notified as soon as possible—preferably within 5 days.
4. File the claim with the following support documents within a 9-month statute of limitations.
 - Original or certified copy of the Bill of Lading, or indemnity bond.
 - Original paid freight bill or indemnity in lieu thereof.
 - Original or certified copy of the invoice, showing trade and other discounts or reductions.
 - Copy of the inspection report issued by carrier’s representative at the time damage is reported to carrier.

The carrier is responsible for making prompt inspection of the damage and for a thorough investigation of each claim. The distributor or manufacturer will not accept claims from dealers for transportation damage.

Electrostatic Discharge (ESD) Precautions

NOTE: Discharge static electricity accumulated in the body before touching the unit. An electrostatic discharge can adversely affect electrical components.

Use the following steps during furnace installations and servicing to protect the integrated control module from damage. By putting the furnace, the control and the person at the same electrostatic potential, these steps will help avoid exposing the integrated control module to electrostatic discharge. This procedure is applicable to both installed and uninstalled (ungrounded) furnaces.

1. Disconnect all power to the furnace.

NOTE: Do not touch the integrated control module or any wire connected to the control prior to discharging your body’s electrostatic charge to ground.
2. Firmly touch a clean, unpainted, metal surface of the furnace away from the control. Any tools held in a person’s hand during grounding will be discharged also.
3. Service the integrated control module or connecting wiring after following the discharge process in Step 2.

NOTE: Do not recharge your body with static electricity by moving or shuffling your feet or touching ungrounded objects. If you touch an ungrounded object, repeat Step 2 before touching the control or wires.
4. Follow steps 1 through 3 before removing a new control from its container or installing the control on a furnace. Return any old or new controls to their containers before touching any ungrounded object.

To the Installer

Before installing this unit, please read this manual thoroughly to familiarize yourself with specific items which must be adhered to, including, but not limited to:

- Unit maximum external static pressure
- Gas pressures
- Btu input rating
- Proper electrical connections
- Circulating air temperature rise
- Minimum or maximum CFM
- Motor speed connections

NOTE: These furnaces are designed for Category I venting only.

Important Note to the Owner Regarding Product Warranty

Your warranty certificate is supplied as a separate document with the unit installed by your contractor. Read the limited warranty certificate carefully to determine what is and is not covered. Keep the warranty certificate in a safe place. If you are unable to locate the warranty certificate, please contact your installing contractor, or contact customer service at 1-866-944-7575 to obtain a copy.

To receive the Lifetime Heat Exchanger Limited Warranty, good for as long as you own your home, and the 10-Year Parts Limited Warranty, online registration must be completed within 60 days of installation. Online registration is not required in California or Quebec.

Full warranty details and instructions for models currently in production are available at www.whirlpoolhvac.com. If your model is not currently in production or does not appear on the website, please contact your installing contractor or contact customer service at 1-866-944-7575 to obtain a copy of your warranty certificate.

To register your unit, go to www.whirlpoolhvac.com. Click on the manufacturer's Comfort Commitment™ Warranty link located at the bottom center of the home page. Next, click on the Click Here to Register Your Product link located at the top center of the page, and complete the forms in the manner indicated.



WARNING

To prevent property damage, personal injury or death due to fire, do not install the furnace in a mobile home, trailer or recreational vehicle.

Product Application

This furnace is primarily designed for residential home-heating applications.

IMPORTANT:

- This furnace is not designed or certified for use in mobile homes, trailers or recreational vehicles.
- This furnace is not designed or certified for outdoor applications.
- The furnace must be installed indoors (for example, attic space, crawl space or garage area provided the garage area is enclosed with an operating door).

This furnace can be used in the following nonindustrial commercial applications:

- | | |
|--------------------|-----------------|
| ■ Schools | ■ Nursing homes |
| ■ Office buildings | ■ Hotels/motels |
| ■ Churches | ■ Common areas |
| ■ Retail stores | ■ Office areas |

NOTE: In such applications, the furnace must be installed with the following stipulations:

- It must be installed according to the installation instructions provided and according to local and national codes.
- It must be installed indoors in a building constructed on site.
- It must be part of a ducted system and not used in a free air delivery application.
- It must not be used as a "makeup" air unit.
- All other warranty exclusions and restrictions apply.

This furnace may be used as a construction site heater only if all of the following conditions are met:

- The vent system is permanently installed according to these installation instructions.
 - A room thermostat is used to control the furnace. Fixed jumpers that provide continuous heating cannot be used.
 - Return air ducts are provided and sealed to the furnace.
 - A return air temperature range between 60°F and 80°F (16°C and 27°C) is maintained.
 - Air filters are installed in the system and maintained during construction, replaced as appropriate during construction and upon completion of construction.
 - The input rate and temperature rise are set according to the furnace rating plate.
 - 100% outside air is provided for combustion air requirements during construction. Temporary ducting can be used.
- NOTE:** Do not connect the temporary duct directly to the furnace. The duct must be sized according to the instructions in the "Combustion and Ventilation Air Requirements" section.
- The furnace heat exchanger, components, duct system, air filters and evaporator coils are thoroughly cleaned following the final construction cleanup.
 - All furnace operating conditions (including ignition, input rate, temperature rise and venting) are verified according to these installation instructions.

NOTE: The Commonwealth of Massachusetts requires that the following additional requirements must also be met:

- Gas furnaces must be installed by a licensed plumber or gas fitter.
- A T-handle gas cock must be used.
- If the unit is to be installed in an attic, the passageway to and the service area around the unit must have flooring.



WARNING

To prevent property damage, personal injury or death due to fire, do not install the furnace in a mobile home, trailer or recreational vehicle.

To ensure proper furnace operation, you must install, operate and maintain the furnace in accordance with these installation and operation instructions, all local building codes and ordinances. In their absence, follow the latest edition of the National Fuel Gas Code (NFPA 54/ANSI Z223.1), and/or CAN/CSA B149 Installation Codes, local plumbing or waste water codes and other applicable codes.

A copy of the National Fuel Gas Code (NFPA 54/ANSI Z223.1) can be obtained from any of the following:

American National Standards Institute
1430 Broadway
New York, NY 10018

National Fire Protection Association
1 Batterymarch Park
Quincy, MA 02269

CSA International
8501 East Pleasant Valley
Cleveland, OH 44131

A copy of the CAN/CSA B149 Installation Codes can also be obtained from:

CSA International
178 Rexdale Boulevard
Etobicoke, Ontario, Canada M9W 1R3

The rated heating capacity of the furnace should be greater than or equal to the total heat loss of the area to be heated. The total heat loss should be calculated by an approved method or in accordance with "ASHRAE Guide" or "Manual J-Load Calculations" published by the Air Conditioning Contractors of America.

In the U.S.A., this furnace must be installed in accordance with the latest edition of the ANSI Z223.1 booklet titled "National Fuel Gas Code" (NFPA 54), and the requirements or codes of the local utility or other authority having jurisdiction. In Canada, this furnace must be installed in accordance with the current CAN/CGA-B149.1 and 2 Gas Installation Codes, local plumbing or waste water codes and other applicable codes. Additional helpful publications available from the NFPA are, NFPA 90A—Installation of Air Conditioning and Ventilating System and NFPA 90B—Warm Air Heating and Air Conditioning System.

All venting shall be in accordance with PART 7, Venting of Equipment, of the National Fuel Gas Code, ANSI Z223.1, or applicable local building and/or air conditioning codes. These publications are available from:

National Fire Protection Association, Inc.
1 Batterymarch Park
Quincy, MA 02269

NOTE: Furnaces with NO_x screens meet the California NO_x emission standards and California seasonal efficiency standards. Annual inspections of the furnace and its vent system is strongly recommended.

LOCATION REQUIREMENTS AND CONSIDERATIONS

Your unit model type determines which installation procedures must be used. For WGFM28 models, you must follow instructions for horizontal left, horizontal right or upflow installations only. These furnaces are not approved for downflow installations.

Downflow models WGFD28 are not approved for horizontal or upflow installations. For these models, use only the instructions for downflow installation only.

WARNING

To prevent possible equipment damage, property damage, personal injury or death, the following bullet points must be observed when installing the unit.

Follow the instructions listed below when selecting a furnace location. Refer also to the guidelines provided in "Combustion and Ventilation Air Requirements."

- Centrally locate the furnace with respect to the proposed or existing air distribution system.
- Check that the temperature of the return air entering the furnace is between 55°F and 100°F (13°C and 38°C) when the furnace is heating.
- Provide provisions for venting combustion products outdoors through a proper venting system.
NOTE: The length of flue piping can be a limiting factor in the location of the furnace.
- Ensure that adequate combustion air is available for the furnace. Improper or insufficient combustion air can expose the building occupants to gas combustion products that could include carbon monoxide. Refer to "Combustion and Ventilation Air Requirements."
- Set the furnace on a level floor. If the floor becomes wet or damp at times, place the furnace above the floor on a concrete base sized approximately 1½" (3.8 cm) larger than the base of the furnace.
- Ensure that the upflow or horizontal furnaces are not installed directly on carpeting, or any other combustible material.

NOTE: The only combustible material allowed is wood.

- Exposure to contaminated combustion air will result in safety and performance-related problems.

NOTE: Do not install the furnace where the combustion air is exposed to the following substances:

- Chlorinated waxes or cleaners
- Chlorine-based swimming pool chemicals
- Water softening chemicals
- Deicing salts or chemicals
- Carbon tetrachloride
- Halogen-type refrigerants
- Cleaning solutions (such as perchloroethylene)
- Printing inks
- Paint removers
- Varnishes
- Hydrochloric acid
- Cements and glues
- Antistatic fabric softeners for clothes dryers
- Masonry acid washing materials

- If the furnace is used in connection with a cooling coil unit, install the furnace upstream or in parallel with the cooling coil unit. Premature heat exchanger failure will result if the cooling coil unit is placed ahead of the furnace.
- If the furnace is installed in an application where the typical operating sound level of a furnace is deemed objectionable, an optional sound reduction kit is available. Consult your local distributor for more details.
- If the furnace is installed in a residential garage, position the furnace so that the burners and ignition source are located not less than 18" (45.7 cm) above the floor. Protect the furnace from physical damage by vehicles.
- If the furnace is installed horizontally, ensure that the furnace access doors are not on the "up/top" or "down/bottom" side of the furnace. The furnace access doors must be vertical so that the burners fire horizontally into the heat exchanger.
- Do not connect the furnace to a chimney flue that serves a separate appliance designed to burn solid fuel.
- On counterflow installations, the air conditioning coil must be downstream from the furnace heat exchanger.

Counterflow Installation Over a Noncombustible Floor

- Before setting the furnace over the plenum opening, ensure that the surface around the opening is smooth and level. A tight seal should be made between the furnace base and floor by using a silicone rubber caulking compound or cement grout.

Counterflow Installation Over a Combustible Floor

- If installation over a combustible floor becomes necessary, use an accessory subbase (see Specification Sheet applicable for your model for details). A special accessory subbase must be used for upright counterflow unit installations over any combustible material, including wood. Refer to subbase instructions for installation details. Follow the instructions with the subbase for proper installation.

NOTES:

- Do not install the furnace directly on carpeting, tile or other combustible material other than wood flooring.
- The subbase will not be required if an air conditioning coil is installed between the supply air opening on the furnace and the floor.

Clearances and Accessibility

Unobstructed front clearance of 24" (61 cm) for servicing is recommended.

Clearances to Combustibles— in. (cm)

Vent Pipe

B1-Vent	Single Wall Connector	Sides	Front	Back	Top (Plenum)
1 (2.5)	6 (15.2)	1 (2.4)	3 (7.6)	0	1 (2.5)

NOTE: Top clearance for horizontal configuration is 1" (2.5 cm).

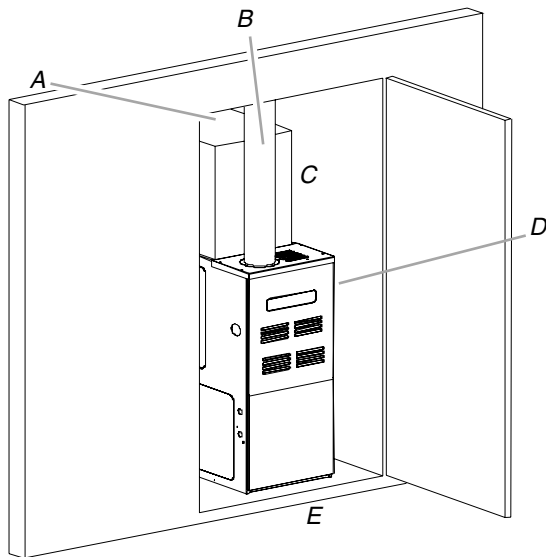

- A. Top clearance—1" (2.5 cm)
 B. Vent pipe clearance—6" (15.2 cm) for single wall connector, 1" (2.5 cm) for B-1 vent
 C. Back clearance—0"
 D. Side clearance—1" (2.5 cm)
 E. Front clearance—3" (7.6 cm)

- Adequate combustion/ventilation air must be supplied to the closet or enclosure.
- Furnace must be completely sealed to the floor or base. Combustion/ventilation air supply pipes must terminate 12" (30.5 cm) from the top of the closet or enclosure and 12" (30.5 cm) from the floor of the closet or enclosure.
NOTE: Do not remove the solid base plate for the side return.
- Return air ducts must be completely sealed to the furnace and terminate outside the enclosure surfaces.

Horizontal Installation—WGFM28 Models Only

Line contact to framing is permitted when installed in the horizontal configuration. Line contact is defined as the portion of the cabinet that is formed by the intersection of the top and side.

IMPORTANT: Accessibility clearance, where greater, should take precedence over minimum fire protection clearance.

- A gas-fired furnace for installation in a residential garage must be installed so that the ignition source and burners are located not less than 18" (45.7 cm) above the floor and are protected or located to prevent physical damage by vehicles.
- A gas furnace must not be installed directly on carpeting, tile, or other combustible materials other than wood flooring.

Furnace Suspension

If suspending the furnace from rafters or joists, use 3/8" threaded rod and 2" x 2" x 1/8" (5.1 cm x 5.1 cm x 3.2 mm) angle iron as shown in "Suspended Furnace" illustration. The length of rod will depend on the application and the clearances necessary.

NOTE: In a horizontal installation, the air conditioning coil must be adequately supported by the proper brackets and supports. Inadequate coil support can result in furnace cabinet distortion and air leakage.

Suspended Furnace

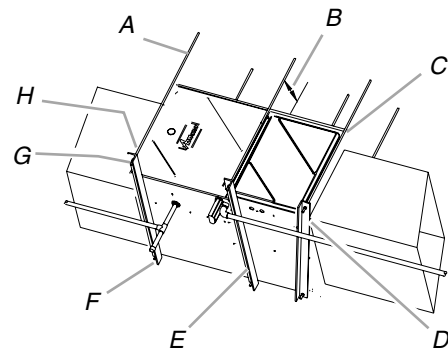

- A. 3/8" (1 cm) diameter threaded rod (6)
 B. 8" (20.3 cm) minimum clearance between center rod and furnace cabinet to allow for circulator blower removal.
 C. Level furnace end to end, slight forward tilt with front 0" to 3/4" (1.9 cm) below back.
 D. Tilt outward to allow for door and circulator blower removal.
 E. Position as close as possible to blower deck to allow for circulator blower removal.
 F. 2" x 2" x 1/8" (5.1 cm x 5.1 cm x 3.2 mm) angle iron (3)
 G. Support nuts
 H. Hold down nuts

Existing Furnace Removal

NOTE: When an existing furnace is removed from a venting system serving other appliances, the venting system may be too large to properly vent the remaining attached appliances.

The following vent testing procedure is reproduced from the American National Standard/National Standard of Canada for Gas-Fired Central Furnaces ANSI Z21.47—latest edition, CSA-2.3 latest edition Section 1.23.1.

The following steps shall be followed with each appliance connected to the venting system placed in operation, while any other appliances connected to the venting system are not in operation:

1. Seal any unused openings in the venting system.
2. Inspect the venting system for proper size and horizontal pitch, as required by the National Fuel Gas Code, ANSI Z223.1 or the Natural Gas and Propane Installation Code, CSA B149.1-05 and these instructions. Determine that there is no blockage or restriction, leakage, corrosion and other deficiencies which could cause an unsafe condition.
3. As far as practical, close all building doors and windows and all doors between the space in which the appliance(s) connected to the venting system are located and other spaces of the building.
4. Close fireplace dampers.
5. Turn on clothes dryers and any appliance not connected to the venting system. Turn on any exhaust fans, such as range hoods and bathroom exhausts, so they shall operate at maximum speed. Do not operate a summer exhaust fan.
6. Follow the lighting instructions. Place the appliance being inspected in operation. Adjust thermostat so appliance shall operate continuously.
7. Test for spillage from draft hood appliances at the draft hood relief opening after 5 minutes of main burner operation. Use the flame of a match or candle.

8. After it has been determined that each appliance connected to the venting system properly vents when tested as outlined above, return doors, windows, exhaust fans, fireplace dampers and any other gas-burning appliance to their previous conditions of use.
9. If improper venting is observed during any of the above tests, the venting system must be corrected in accordance with the National Fuel Gas Code, ANSI Z223.1/NFPA 54 and/or Natural Gas and Propane Installation Code, CSA B149.1-05.

If resizing is required on any portion of the venting system, use the appropriate table in Appendix G in the latest edition of the National Fuel Gas Code, ANSI Z223.1 and/or Natural Gas and Propane Installation Code, CSA B149.1-05.

Thermostat Location

The thermostat should be placed approximately 5 ft (1.5 m) from the floor on a vibration-free, inside wall in an area having good air circulation.

NOTE: Do not install the thermostat where it may be influenced by any of the following:

- Drafts, or dead spots behind doors, in corners or under cabinets
- Hot or cold air from registers
- Radiant heat from the sun
- Light fixtures or other appliances
- Radiant heat from a fireplace
- Concealed hot or cold water pipes or chimneys
- Unconditioned areas behind the thermostat, such as an outside wall

Consult the instructions packaged with the thermostat for mounting instructions and further precautions.

COMBUSTION AND VENTILATION AIR REQUIREMENTS

WARNING

To avoid property damage, personal injury or death, sufficient fresh air for proper combustion and ventilation of flue gases must be supplied. Most homes require outside air be supplied into the furnace area.

Improved construction and additional insulation in buildings have reduced heat loss by reducing air infiltration and escape around doors and windows. These changes have helped in reducing heating/cooling costs but have created a problem supplying combustion and ventilation air for gas-fired and other fuel-burning appliances. Appliances that pull air out of the house (clothes dryers, exhaust fans, fireplaces, etc.) increase the problem by starving appliances for air.

House depressurization can cause back drafting or improper combustion of gas-fired appliances, thereby exposing building occupants to gas combustion products that could include carbon monoxide.

If this furnace is to be installed in the same space with other gas appliances, such as a water heater, ensure that there is an adequate supply of combustion and ventilation air for the other appliances. Refer to the latest edition of the National Fuel Gas Code NFPA 54/ANSI Z223.1 or Natural Gas and Propane Installation Code, CSA B149.1-05 or applicable provisions of the local building codes for determining the combustion air requirements for the appliances.

NOTE: This furnace must use indoor air for combustion. It cannot be installed as a direct vent, or sealed combustion, furnace.

Most homes will require outside air to be supplied to the furnace area by means of ventilation grilles or ducts connecting directly to the outdoors or spaces open to the outdoors such as attics or crawl spaces.

Category I Venting—Vertical Venting

WARNING

To prevent possible personal injury or death due to asphyxiation, this furnace must be Category I vented. Do not vent using Category III venting. Provisions must be made for venting combustion products outdoors through a proper venting system. The length of flue pipe could be a limiting factor in locating the furnace.

Category I Venting is venting at a nonpositive pressure. A furnace vented as Category I is considered a fan-assisted appliance. The vent system does not have to be “gas tight.”

NOTE: Single-stage gas furnaces with induced draft blowers draw products of combustion through a heat exchanger allowing, in some instances, common venting with natural draft appliances (for example, water heaters).

All installations must be vented in accordance with National Fuel Gas Code NFPA 54/ANSI Z223.1—latest edition. In Canada, the furnaces must be vented in accordance with the National Standard of Canada, CAN/CSA B149.1 and CAN/CSA B149.2—latest editions and amendments.

NOTE: The vertical height of the Category I venting system must be at least as great as the horizontal length of the venting system.

 **WARNING**

To prevent possible personal injury or death, due to asphyxiation, common venting with other manufacturer's induced draft appliances is not allowed.

The minimum vent diameter for the Category I venting system is as shown in the Minimum Vent chart.

Minimum Vent		
Model	Upflow	Counterflow
70	4" (10.2 cm)	4" (10.2 cm)
90	4" (10.2 cm)	4" (10.2 cm)
115	5" (12.7 cm)	4" (10.2 cm)

Under some conditions, larger vents than those shown in the Minimum Vent chart may be required or allowed. When an existing furnace is removed from a venting system serving other appliances, the venting system may be too large to properly vent the remaining attached appliances.

Upflow or horizontal units are shipped with the induced draft blower discharging from the top of the furnace. ("Top" is as viewed for an upflow installation.) The induced draft blower can be rotated 90 degrees with the Chimney Transition Bottom kit (0270F01119) for Category I venting. For horizontal installations, a 4" (10.2 cm) single-wall pipe can be used to extend the induced draft blower outlet ½" (1.3 cm) beyond the furnace cabinet.

NOTE: This product is not designed for counterclockwise induced draft blower rotation.

Vent the furnace in accordance with the National Fuel Gas Code NFPA 54/ANSI Z223.1—latest edition. In Canada, vent the furnace in accordance with the National Standard of Canada, CAN/CSA B149.1 and CAN/CSA B149.2—latest editions and amendments.

Venting—Furnace Installed in Horizontal Position

NOTE: This furnace is not design certified to be horizontally vented through an exterior side wall.

The following describes an optional venting procedure when the furnace is installed in the horizontal left discharge position.

To rotate the induced draft blower clockwise, you will need to purchase one chimney transition bottom kit (Part Number 0270F01119).

1. Disconnect electrical power from the furnace.
2. Disconnect the induced draft blower power leads, flue pipe and pressure switch tubing.
3. Remove the round cutout from the right side of the wrapper.
4. Remove and save the 4 screws that fasten the induced draft blower to the flue collector box.
5. Remove and save the 3 screws that hold the chimney assembly to the induced draft blower.

6. Remove and save the 4 screws that fasten the chimney top to the chimney bottom.
7. Remove the chimney transition bottom from the transition bottom kit.
8. Install the chimney top with the 4 screws retained from Step 6 onto the new chimney transition bottom from the transition bottom kit.
9. Remove the induced draft blower and install the new chimney assembly to it using the 3 screws retained in Step 5.
10. Rotate the induced draft blower 90 degrees to the right, feeding the flue pipe through the round cutout from the outside of the wrapper, and fitting the blower onto the chimney top assembly.
11. Secure the pipe to the chimney top from the front, top and bottom using 3 screws. Rotate the induced draft blower to properly orient the assembly.

NOTE: If the pipe section is less than 18" (45.7 cm), then attach it directly to the chimney top on 3 sides, and feed it through the round cutout from the inside of the wrapper.
12. Reattach the induced draft blower using the 4 screws retained in Step 4. Ensure that the gasket located between the induced draft blower and collector box is rotated accordingly.
13. Reconnect the induced draft blower power leads.

NOTE: If the wires are not long enough, pull extra wire from the wire bundle in the blower compartment.
14. Reconnect the remaining flue pipe and the pressure switch tubing. Ensure that all wires and the pressure switch tubing are at least 1" (2.5 cm) from the flue pipe, or any other hot surface.
15. Reconnect electrical power to the furnace.

NOTE: In a horizontal installation, the air conditioning coil must be adequately supported by the proper brackets and supports. Inadequate coil support can result in furnace cabinet distortion and air leakage.

Category I Furnaces Only—Exterior Masonry Chimneys

An exterior masonry chimney is defined as a "Masonry chimney exposed to the outdoors on one or more sides below the roof line." The ability to use a clay-lined masonry chimney depends on a parameter not associated with interior chimneys. This variable is the geographic location of the installation. Researchers have discovered that the winter design temperatures have a direct impact on the suitability of this type of venting. In most situations, the existing masonry chimneys will require a properly-sized metallic liner.

Counterflow units are shipped with the induced draft blower discharging from the top (as viewed for a counterflow installation) of the furnace.

Vent the furnace in accordance with the National Fuel Gas Code NFPA 54/ANSI Z223.1—latest edition. In Canada, vent the furnace in accordance with the National Standard of Canada, CAN/CSA B149.1 AND CAN/CSA B149.2—latest editions and amendments.

 **WARNING**

Never allow the products of combustion, including carbon monoxide, to enter the return ductwork or circulation air supply.



WARNING

Possibility of property damage, personal injury or death. Damaging condensation can occur inside masonry chimneys when a single fan-assisted Category I appliance (80% AFUE furnace) is vented without adequate dilution air. Do not connect an 80% furnace to a masonry chimney unless the furnace is common vented with a draft hood equipped appliance or the chimney is lined with a metal liner or Type B metal vent. All installations using masonry chimneys must be sized in accordance with the appropriate venting tables. If an 80% furnace is common vented with a draft hood equipped appliance, the potential for condensation damage may still exist with extremely cold conditons, long vent connectors, exterior chimneys or any combination of these conditions. The risk of condensation damage is best avoided by using the masonry chimney as a pathway for properly-sized metal liner or Type B metal vent.

Typical Multiple Flue Clay Tile Chimney

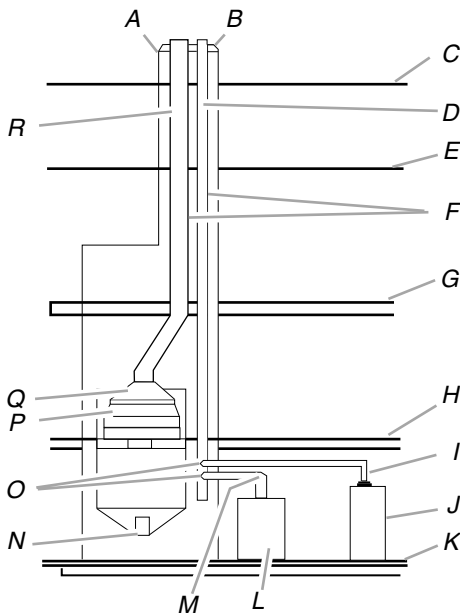

- | | | |
|--------------------------------------------------------------------------------------------|------------------------------------|---------------------------------------------------------------------------------|
| A. Crown | G. Second floor | M. Forced air furnace vent connector |
| B. Wash | H. First floor | N. Clean out |
| C. Roof line | I. Water heater vent connector | O. Breech |
| D. Clay tile size: 8" x 8" x 12" (24.3 cm x 24.3 cm x 30.5 cm) (each x 24" [61 cm] length) | J. Natural draft water heater | P. Damper |
| E. Attic floor | K. Basement floor | Q. Throat |
| F. ½" to 1" (1.3 cm to 2.5 cm) air space | L. Fan-assisted forced air furnace | R. Clay tile size: generally 12" x 12" (30.5 cm x 30.5 cm) (24" [61 cm] length) |

Checklist Summary

This checklist serves as a summary of the items to be checked before venting an 80+ furnace into a masonry chimney. In addition, we recommend that a qualified serviceman use this checklist to perform a yearly inspection of the furnace venting system.

This checklist is only a summary. For detailed information on each of the procedures mentioned, see the paragraph referenced with each item.

This inspection is based upon a draft topical report, "Masonry Chimney Inspection and Relining," issued by the Gas Research Institute. While not yet finalized, we believe this report represents the best information on this subject which is currently available.

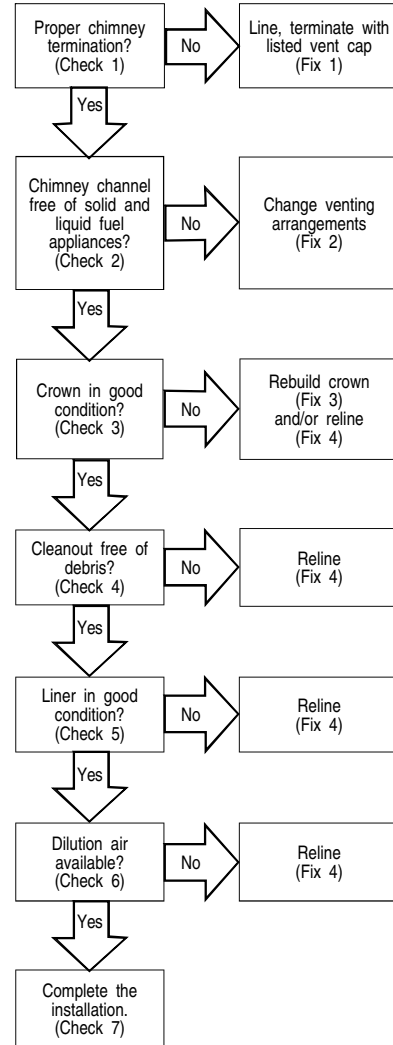

Check 1 – Proper Chimney Termination

A masonry chimney used as a vent for gas-fired equipment must extend at least 3 ft (91.4 cm) above the highest point where it passes through the roof. It must extend at least 2 ft (61 cm) higher than any portion of a building within a horizontal distance of 10 ft (3 m). In addition, the chimney must terminate at least 3 ft (91.4 cm) above any forced air inlet located within 10 ft (3 m). The chimney must extend at least 5 ft (1.5 m) above the highest connected equipment draft hood outlet or flue collar.

If the chimney does not meet these termination requirements, but all other requirements in the checklist can be met, it may be possible for a mason to extend the chimney. If this will not be practical, see “Fix 1—Liner Termination.”

Termination 10 ft (3 m) or Less From Ridge, Wall or Parapet

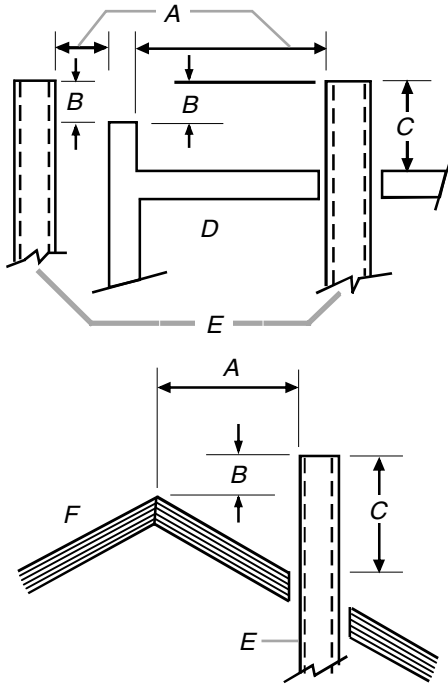

- A. 10 ft (3 m) or less
- B. 2 ft (61 cm) minimum
- C. 3 ft (91.4 cm) minimum
- D. Wall or parapet
- E. Chimney(s)

Termination More Than 10 ft (3 m) From Ridge, Wall or Parapet

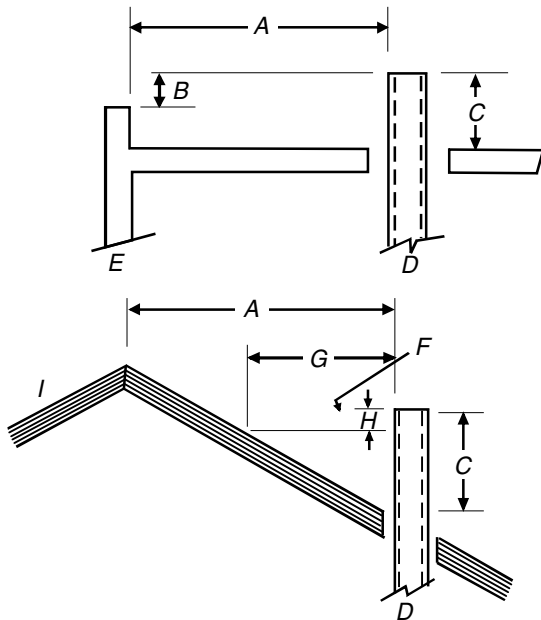

- A. More than 10 ft (3 m)
- B. No height above parapet required when distance from walls or parapet is more than 10 ft (3 m).
- C. 3 ft (91.4 cm) minimum
- D. Chimney
- E. Wall or parapet
- F. Height above any roof surface within 10 ft (3 m) horizontally
- G. 10 ft (3 m)
- H. 2 ft (61 cm) minimum
- I. Ridge

Check 2—Any Solid or Liquid Fuel Appliances Vented into This Chimney Channel

Solid fuel appliances include fireplaces, wood stoves, coal furnaces and incinerators.

Liquid fuel appliances include oil furnaces, oil-fired boilers and oil-fired water heaters.

Appliances which burn propane (sometimes referred to as LP [liquefied petroleum]) gas are considered gas-fired appliances.

Check 3—Chimney Crown Condition

Damage from condensate normally appears first in the crown. If any of the following trouble signs are present, the condition of the crown is not satisfactory.

- Crown leaning—“Fix 3—Rebuild the Crown”
- Bricks missing—“Fix 3—Rebuild the Crown”
- Mortar missing—“Fix 3—Rebuild the Crown”
- Tile liner cracked—“Fix 4—Relining”
- No tile liner—“Fix 4—Relining”
- Salt staining at mortar joints (white stains and mortar becomes sandy and/or erodes)—“Fix 4—Relining”

IMPORTANT: It may be necessary to follow both “Fix 3—Rebuild the Crown” and “Fix 4—Relining.”

Check 4—Debris in Cleanout

A cleanout (dropleg) must be in a location where the upper edge of the cleanout cover is at least 12" (30.5 cm) below the lower edge of the lowest chimney inlet opening.

A chimney without a cleanout could become partially blocked by debris. If no cleanout is present, the chimney must be relined (Fix 4—Relining). Remove the cleanout cover, and examine the cleanout for debris. If significant amounts of any of the following are found, reline the chimney (Fix 4—Relining).

- Fuel oil residue
- Bricks
- Mortar or sand
- Pieces of the tile liner
- Rusted pieces of the metallic liner

Check 5—Liner Condition

If a metal liner is present, it must be checked. It cannot be assumed that all existing metal liners are correctly installed and in good condition.

Remove the lowest existing vent connector and examine the inside of the elbow or tee at the base of the liner. A small amount of soot may be considered acceptable, provided the installer vacuums it away. If rusted pieces of the liner have collected here, the metal liner must be removed and replaced (Fix 4—Relining).

Next, gently tap the inside of the liner with a Phillips screwdriver. If the screwdriver perforates the liner, or if the tapping does not sound like metal hitting metal, the liner must be removed and replaced (Fix 4—Relining).

REMEMBER: All appliances must be vented inside the liner. Venting one appliance inside the liner and another appliance outside the liner is not acceptable.

Next, use a flashlight and a small mirror to look up inside the liner. B-vent must be supported so as to not come into direct contact with the chimney walls or tile liner. If it is not, it can probably be rehung so as to be acceptable. A thimble or fire stop may be helpful here.

Flexible liners should be hung straight or nearly straight. If it is spiraled in the chimney and in good condition, it should be rehung. To do this, break the top seal. Pull up and cut off the excess liner length and refit the top seal. Use caution when doing this, since the cut edges of flexible liners may be sharp.

The surfaces of the liner must be physically sound. If gaps or holes are present, the metal liner must be removed and replaced (Fix 4—Relining). Finally, confirm that the metal liner is the correct size for the appliances to be installed. Use the GAMA tables and rules.

NOTE: If a metal liner is not present, a clay tile liner must be present, or the chimney must be lined (Fix 4—Relining).

Use a flashlight and small mirror at the cleanout or vent connector to inspect the clay tile liner. If any of the following problems are present, reline (Fix 4—Relining).

- Tile sections misaligned
- Tile sections missing
- Gaps between tile sections
- Signs of condensate drainage at the cleanout or vent connectors
- Mortar protruding from between tile sections
- Use of sewer pipe or drainage pipe rather than an approved fire clay tile

Next, measure the size of the liner. It may be possible to do this from the cleanout. The liner must be at least as large as the minimum size established by the tables in National Fuel Gas Code NFPA 54/ANSI Z223.1—latest edition and in the National Standard of Canada, CAN/CSA B149.1 and CAN/CSA B149.2—latest editions and amendments. If the liner is too small or too large, then the chimney must be relined (Fix 4—Relining).

Check 6—Dilution Air

If gas-fired appliances are to be vented into a clay tile liner, a source of dilution air is required.

Dilution air cannot be obtained through the following:

- Induced draft appliances
- Natural draft appliances with vent dampers

Sufficient dilution air can ordinarily be obtained through the draft hood of a natural draft appliance only if the appliance's vent connector does not include a vent damper. If dilution air will not be available, the chimney must be relined (Fix 4—Relining).

Check 7—Complete the Installation

If checks 1 through 6 have been satisfactory, and the liner is an acceptable size as determined by the tables in National Fuel Gas Code NFPA 54/ANSI Z223.1—latest edition and in the National Standard of Canada, CAN/CSA B149.1 and CAN/CSA B149.2—latest editions and amendments, then the clay tile liner can probably be used as a vent for the gas appliances. However, the installer must keep in mind the following factors which may render the tile liner unsuitable for use as a vent:

- Extremely cold weather
- Long vent connectors
- Masonry chimneys with no air gap between the liner and the bricks—difficult to detect
- Exterior chimneys (the tables in National Fuel Gas Code NFPA 54/ANSI Z223.1—latest edition and in the National Standard of Canada, CAN/CSA B149.1 and CAN/CSA B149.2—latest editions and amendments assume interior chimneys)

If, in the judgment of the local gas utility, installer and/or local codes, one or more of the above factors is likely to present a problem, the chimney must be relined (Fix 4—Relining).

Fix 1—Liner Termination

Any cap or roof assembly used with a liner must be approved by the liner manufacturer for such use. The liner and cap/roof assembly must then terminate above the roof in accordance with the manufacturer's instructions.

In some cases, a shorter extension above the roof may be possible with a liner than would be required with a masonry chimney.

For further information on relining, see "Fix 4—Relining."

Fix 2—Change Venting Arrangements

If the masonry chimney has more than one channel, it may be possible to vent the gas appliances into one channel and vent the solid or liquid fuel appliance(s) into another channel(s). Do not vent an 80+ furnace inside of a metal liner with other appliances vented outside the liner.

Alternatively, the homeowner may agree to discontinue use of the fireplace (solid fuel appliance). If so, the tile liner must be cleaned to remove creosote buildup. The fireplace opening must then be permanently sealed.

If oil-fired appliance(s) are being replaced by gas-fired appliance(s), the tile liner must first be cleaned to remove the fuel oil residue.

If none of the above options is practical, the furnace may need to be vented vertically with a B-vent.

Under some conditions, a 90%+ furnace could be installed rather than an 80% furnace. The 90%+ furnace can be vented horizontally or vertically through PVC pipe.

Fix 3—Rebuild the Crown

If the chimney crown is damaged, a qualified mason must repair it in accordance with nationally recognized building codes or standards. One such standard which may be referenced is the Standard for Chimneys, Fireplaces, Vents, and Solid Fuel Burning Appliances, ANSI/NFPA 211.

Fix 4—Relining

Relining options include B-vent and flexible liners.

If the chimney has diagonal offsets, B-vent probably cannot be used.

If B-vent is to be used, it must be supported adequately. Supports (such as fire stops or thimbles) must be used to keep the B-vent from coming into direct contact with the tile liner or chimney walls. Direct contact would result in higher heat loss, with an increased possibility of poor venting system performance.

It is not acceptable to vent one appliance inside the B-vent and other appliances outside.

The excess space between the B-vent and the chimney walls must be covered at the top of the chimney by a weatherproof, corrosion resistant flashing. The B-vent should then be topped with a listed vent cap. The listed vent cap will, when installed according to the manufacturer's instructions, prevent problems due to rain, birds or wind effects.

A B-vent installed as described in this section is considered to be an enclosed vent system, and the sizing tables in National Fuel Gas Code NFPA 54/ANSI Z223.1—latest edition and in the National Standard of Canada, CAN/CSA B149.1 and CAN/CSA B149.2—latest editions and amendments may be used.

If a flexible liner is to be used, it must be made of the proper materials, such as:

- For most residential applications, an aluminum liner should be acceptable.
- If the combustion air supplied to the furnace will be contaminated with compounds containing chlorine or fluorine, a liner of AL 29-4C stainless steel should be used. Common sources of chlorine and fluorine compounds include indoor swimming pools and chlorine bleaches, paint strippers, adhesives, paints, varnishes, sealers, waxes (which are not yet dried) and solvents used during construction and remodeling. Various commercial and industrial processes may also be sources of chlorine/fluorine compounds.
- Heavier gauge 300 and 400 series stainless steel liners were developed for use with oil or solid-fuel appliances. They are not suitable for use with gas-fired appliances. Flexible liners specifically intended and tested for gas applications are listed in the UL "Gas and Oil Equipment Directory" (UL Standard 1777).

For sizing of flexible liners, see Note 22 and the tables in the National Fuel Gas Code NFPA 54/ANSI Z223.1—latest edition and in the National Standard of Canada, CAN/CSA B149.1 and CAN/CSA B149.2—latest editions and amendments.

To install the liner, read and follow the liner manufacturer's instructions and your local codes. Excess liner length should be pulled out of the chimney and cut off.

NOTES:

- Use caution when doing this, as the cut edges of flexible liners may be sharp.

- Do not spiral excess liner inside of the chimney.
- Support the liner as recommended by the liner manufacturer. Some manufacturers of flexible liners offer an insulation sleeve designed to be added to the liner before it is installed in the chimney.

NOTE: Poured insulation, either vermiculite or other materials, is no longer recommended.

Insulation will need to be added to the flexible liner if:

- It is required by the liner manufacturer's instructions.
- The previous liner was properly sized and installed, and suffered from condensation damage.
- It is required by your local building codes.



Even if none of the 3 conditions exist which require additional liner insulation, the installer may wish to consider installing additional insulation if:



- The local climate is very cold.
- The chimney is very tall.
- The vent connectors used are very long or have a large number of elbows.
- Local experience indicates that flexible liners installed without insulation are likely to have condensation problems.

Insulation must be selected and installed in accordance with the liner manufacturer's instructions.

Finally, cap the chimney and terminate the liner in accordance with the liner manufacturer's instructions.

ELECTRICAL CONNECTIONS

	WARNING
HIGH VOLTAGE!	
To avoid the risk of electrical shock, wiring to the unit must be polarized and grounded.	
	

	WARNING
HIGH VOLTAGE!	
To avoid personal injury or death due to electrical shock, disconnect electrical power before servicing or changing any electrical wiring.	
	

	CAUTION
Label all wires prior to disconnection when servicing controls. Wiring errors can cause improper and dangerous operation. Verify proper operation after servicing.	

	WARNING
HIGH VOLTAGE!	
To avoid the risk of injury, electrical shock or death, the furnace must be electrically grounded in accordance with local codes or in their absence, with the latest edition of the National Electric Code (NEC).	
	

Wiring Harness

The wiring harness is an integral part of this furnace. Field alteration to comply with electrical codes should not be required. Wires are color coded for identification purposes. Refer to the wiring diagram for wire routings. If any of the original wire as supplied with the furnace must be replaced, it must be replaced with wiring material having a temperature rating of at least 105°C. Any replacement wiring must be a copper conductor.

115-Volt Line Connections

Before proceeding with electrical connections, ensure that the supply voltage, frequency and phase correspond to that specified on the unit rating plate. Power supply to the furnace must be NEC Class 1, and must comply with all applicable codes. The furnace must be electrically grounded in accordance with local codes or, in their absence, with the latest edition of The National Electric Code, ANSI NFPA 70 and/or The Canadian Electric Code CSA C22.1.

Use a separate fused-branch electrical circuit containing properly sized wire, and fuse or circuit breaker. The fuse or circuit breaker must be sized in accordance with the maximum overcurrent protection specified on the unit rating plate. An electrical disconnect must be provided at the furnace location.

Connect hot, neutral and ground wires as shown in the wiring diagram located on the unit's blower door.

Line polarity must be observed when making field connections. Line voltage connections can be made through either the right or left side panel. The furnace is shipped configured for a right side (right side for counterflows or blower compartment for downflows) electrical connection with the junction box located inside the burner compartment.

To make electrical connections through the opposite side of the furnace, the junction box must be relocated to the other side of the burner or blower compartment prior to making electrical connections.

To relocate the junction box, follow the steps shown in “Junction Box Relocation.”

NOTE: Wire routing must not to interfere with circulator blower operation, filter removal or routine maintenance.

Junction Box Relocation

WARNING

Edges of sheet metal holes may be sharp. Use gloves as a precaution when removing hole plugs.

Line voltage connections can be made through either the right or left side panel. The furnace is shipped configured for a left side electrical connection. To make electrical connections through the opposite side of the furnace, the junction box must be relocated to the left side prior to making electrical connections. To relocate the junction box, perform the following steps.

WARNING

To prevent personal injury or death due to electric shock, disconnect electrical power before installing or servicing this unit.

1. Remove both doors from the furnace.
2. Remove and save the screws securing the junction box to the right side of the furnace.
3. Models that have the junction box located in the burner or blower compartment will need to move the junction box directly over.
4. Attach the junction box to the left side of the furnace using the screws removed in Step 2.
5. Check the location of the wiring. Confirm that it will not be damaged by heat from the burners or by the rotation of the fan. Also confirm that wiring location will not interfere with filter removal or other maintenance.

After the junction box is in the desired location, use washers to connect field-supplied conduit to the junction box in accordance with NEC and local codes. Connect hot, neutral, and ground wires as shown in the furnace wiring diagram. The wires and ground screw are located in the furnace junction box.

NOTES:

- In downflow applications, the power leads should be routed through the supplied wire tabs when locating the junction box to the left side.
- Low voltage wires may be connected to the terminal strip.

IMPORTANT: To avoid possible equipment malfunction, route the low voltage wires to avoid interference with filter removal or other maintenance.

WARNING

HIGH VOLTAGE!

To avoid the risk of injury, electrical shock or death, the furnace must be electrically grounded in accordance with local codes or in their absence, with the latest edition of the National Electric Code (NEC).



To ensure proper unit grounding, the ground wire should run from the furnace ground screw located inside the furnace junction box all the way back to the electrical panel.

NOTE: Do not use gas piping as an electrical ground.

To confirm proper unit grounding, turn off the electrical power and perform the following check.

1. Measure the resistance between the neutral (white) connection and one of the burners.
2. Resistance should measure 10 ohms or less.

This furnace is equipped with a blower door interlock switch which interrupts the unit voltage when the blower door is opened for servicing.

NOTE: Do not defeat this switch.

24-Volt Thermostat Wiring

IMPORTANT NOTE

Wire routing must not interfere with circulator blower operation, filter removal or routine maintenance. A removable plug connector is provided with the control to make thermostat wire connections. This plug may be removed to allow wire connections to be made to the plug and then replaced. It is STRONGLY recommended that multiple wires into a single terminal be twisted together prior to inserting into the plug connector. Failure to do so may result in intermittent operation.

As a 2-stage furnace, the furnace integrated control module provides terminals for both W1 and W2, and Y1 and Y2 thermostat connections. This allows the furnace to support the following system applications: 2-stage heating only, 2-stage heating with single-stage cooling and 2-stage heating with 2-stage cooling. Refer to the following thermostat wiring diagrams for proper connections to the integrated control module.

Low voltage connections can be made through either the right or left side panel. Thermostat wiring entrance holes are located in the blower compartment. The following illustration shows the connections for a heat/cool system.

This furnace is equipped with a 40 VA transformer to facilitate use with most cooling equipment. Consult the wiring diagram located on the blower compartment door for further details of 115-volt and 24-volt wiring.

NOTES:

- For single-stage cooling applications, a jumper may be required between Y1 and Y2 at the furnace control in order to achieve the desired single-stage cooling airflow. Consult the Blower Performance charts to determine if the required single-stage cooling airflow can be delivered at low stage (Y1 input) or high stage (Y2 input). Additionally, use of ramping profile and dehumidification features require a jumper between Y1 and O and Y1 and DEHUM, respectively.
- Thermostat R required if outdoor unit is equipped with a Comfort Alert™ module.

Thermostat Wiring Diagram—Single-Stage Thermostat Application

NOTE: Place jumper between Y1 and O for proper dehumidification operation and proper ramping profile operation.

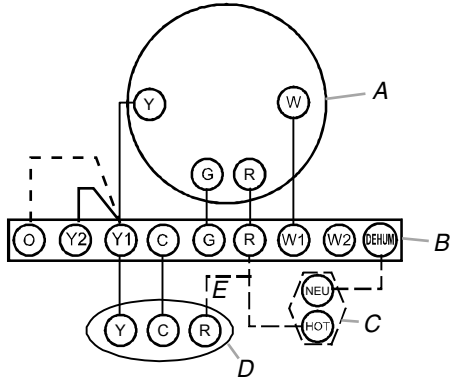

- A. Thermostat—single-stage heating and single-stage cooling
- B. Furnace integrated control module
- C. Dehumidistat (optional)
- D. Remote condensing unit (single-stage cooling)
- E. Thermostat R required if outdoor unit is equipped with a Comfort Alert™ module.

NOTE: To apply a single-stage heating thermostat, the thermostat selector switch on the integrated control module must be set on single-stage.

Thermostat Wiring Diagram—2-Stage Heating with Single-Stage Cooling

NOTE: Place jumper between Y1 and O for proper dehumidification operation and proper ramping profile operation.

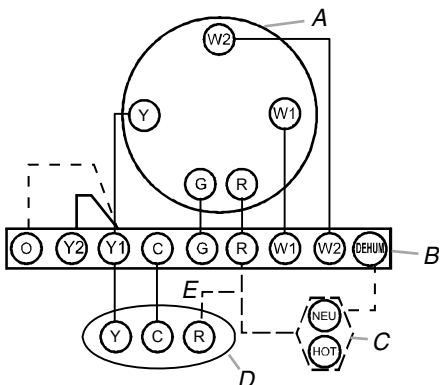

- A. Thermostat—2-stage heating and single-stage cooling
- B. Furnace integrated control module
- C. Dehumidistat (optional)
- D. Remote condensing unit (single-stage cooling)
- E. Thermostat R required if outdoor unit is equipped with a Comfort Alert™ module.

Thermostat Wiring Diagram—2-Stage Heating with 2-Stage Cooling

NOTE: Place jumper between Y1 and O for proper dehumidification operation and proper ramping profile operation.

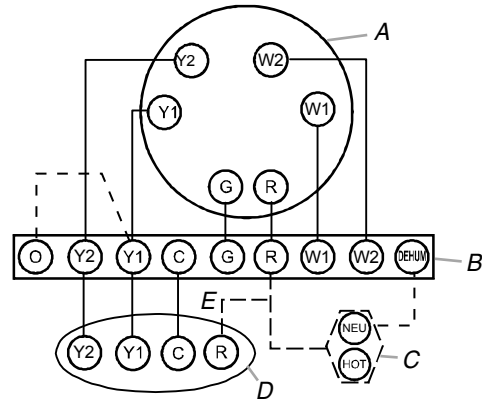

- A. Thermostat—2-stage heating and 2-stage cooling
- B. Furnace integrated control module
- C. Dehumidistat (optional)
- D. Remote condensing unit (2-stage cooling)
- E. Thermostat R required if outdoor unit is equipped with a Comfort Alert™ module.

A single-stage thermostat with only 1 heating stage may be used to control this furnace. The application of a single-stage thermostat does not offer true thermostat-driven 2-stage operation, but provides a timed transition from low to high fire. The furnace will run on low stage for a fixed period of time before stepping up to high stage to satisfy the thermostat's call for heat. The delay period prior to stepping up can be set at either a fixed 5-minute transition time or a load based variable time between 1 and 12 minutes (Auto transition). If the Auto transition mode is selected, the control averages the cycle times of the previous 3 cycles and uses the average to determine the time to transition from low stage to high stage.

To use a single-stage thermostat:

1. Turn off power to the furnace.
2. Move the thermostat selection DIP switch to the Off (single-stage) position.
3. Set the desired transition time by setting the Stage Delay DIP switch to On for Auto transition, or Off for 5-minute transition time.
4. Turn on power. Refer to the following illustration.

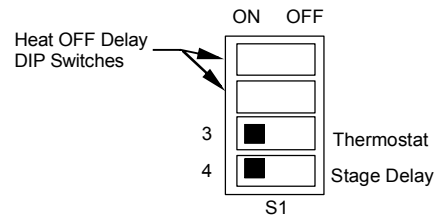

24-Volt Dehumidistat Wiring

The optional usage of a dehumidistat allows the furnace's circulator blower to operate at a slightly lower speed (82% of desired speed) during a combined thermostat call for cooling and dehumidistat call for dehumidification. This can be done through an independent dehumidistat or through a thermostat's DEHUM terminal (if available). This lower blower speed enhances dehumidification of the conditioned air as it passes through the AC coil. For proper function, a dehumidistat applied to this furnace must operate on 24 VAC and utilize a switch which opens on humidity rise.

To install/connect a dehumidistat:

1. Turn off power to furnace.
 2. Secure the dehumidistat neutral wire (typically the white lead) to the terminal marked DEHUM on the furnace integrated control module.
 3. Secure the dehumidistat hot wire (typically the black lead) to the terminal marked R on the furnace integrated control module.
 4. Secure the dehumidistat ground wire (typically the green lead) to the ground screw on the furnace junction box.
- NOTE:** Ground wire may not be present on all dehumidistats.
5. Turn on power to furnace.

To enable the dehumidify function on the integrated control module, set the dehumidification DEHUM DIP switch from Off to On.

Once the switch is set, the dehumidify function is enabled during a combination call for cooling (T-Stat) and dehumidification (DEHUM-Stat).

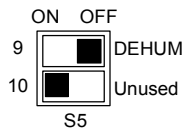

Fossil Fuel Applications

This furnace can be used in conjunction with a heat pump in a fossil fuel application. A fossil fuel application refers to a combined gas furnace and heat pump installation which uses an outdoor temperature sensor to determine the most cost efficient means of heating (heat pump or gas furnace).

A heat pump thermostat with 3 stages of heat is required to properly use a 2-stage furnace in conjunction with a heat pump. Refer to the fossil fuel kit installation instructions for additional thermostat requirements.

Strictly follow the wiring guidelines in the fossil fuel kit installation instructions. All furnace connections must be made to the furnace 2-stage integrated control module and the FURNACE terminal strip on the fossil fuel control board.

115-Volt Line Connection of Accessories (Humidifier and Electronic Air Cleaner)

WARNING

HIGH VOLTAGE!

To avoid personal injury or death due to electrical shock, disconnect electrical power before servicing or changing any electrical wiring.



The furnace integrated control module is equipped with line voltage accessory terminals for controlling power to an optional field-supplied humidifier and/or electronic air cleaner.

The accessory load specifications are as follows:

Humidifier	1.0 Amp maximum at 120 VAC
Electronic Air Cleaner	1.0 Amp maximum at 120 VAC

NOTES:

- Turn off power to the furnace before installing any accessories.
- Follow the humidifier or air cleaner manufacturers' instructions for locating, mounting, grounding and controlling these accessories.
- Accessory wiring connections are to be made through the 1/4" quick connect terminals provided on the furnace integrated control module.
- The humidifier and electronic air cleaner hot terminals are identified as HUM and EAC.
- The humidifier and electronic air cleaner neutral terminals are identified as NEUTRAL.
- All field wiring must conform to applicable codes.
- Connections should be made as shown in the "Optional Accessories Wiring" illustration.

Optional Accessories Wiring

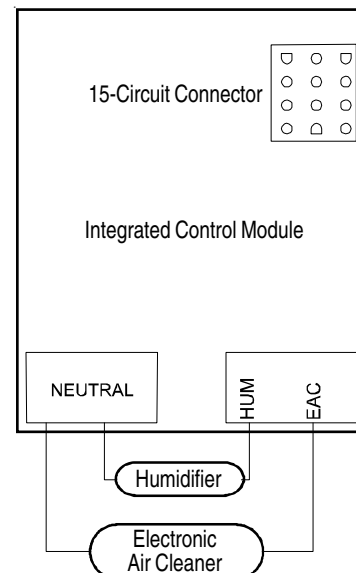

If it is necessary for the installer to supply additional line voltage wiring to the inside of the furnace, the wiring must conform to all local codes, and have a minimum temperature rating of 105°C. All line voltage wire splices must be made inside the furnace junction box.

The integrated control module humidifier terminals (HUM) are energized with 115 volts whenever the induced draft blower is energized. The integrated control module electronic air cleaner terminals (EAC) are energized with 115 volts whenever the circulator blower is energized.

24-Volt Humidifier

A 5" (12.7 cm) long brown wire in the wire harness at the low-fire pressure switch provides 24 VAC humidifier control. This wire is powered any time the pressure switch is closed. To connect 24 VAC HUM, connect the 24 VAC line of the humidifier to the 5" (12.7 cm) brown wire. The connection can be made by either stripping the wire and using a wire connector or by using a field-supplied quick connect terminal. The wiring must conform to all local and national codes. Connect the COM side of the humidifier to the C terminal on the furnace control board (or to the COM side of the 24 VAC transformer).

NOTE: Do not connect 115-volt humidifier to these terminals.

GAS SUPPLY AND PIPING

The furnace rating plate includes the approved furnace gas input rating and gas types. The furnace must be equipped to operate on the type of gas applied. This includes any conversion kits required for alternate fuels and/or high altitude.

CAUTION

To prevent unreliable operation or equipment damage, the inlet gas supply pressure must be as specified on the unit rating plate with all other household gas-fired appliances operating.

Inlet gas supply pressures must be maintained within the ranges specified in the Inlet Gas Supply Pressure chart. The supply pressure must be constant and available with all other household gas-fired appliances operating. The minimum gas supply pressure must be maintained to avoid unreliable ignition. The maximum must not be exceeded to keep the furnace from overfiring.

Inlet Gas Supply Pressure

Natural gas 5.0" W.C. minimum; 10.0" W.C. maximum

Propane gas 11.0" W.C. minimum; 13.0" W.C. maximum

NOTE: Adjusting the minimum supply pressure below the limits in the Inlet Gas Supply Pressure chart could lead to unreliable ignition. Gas input to the burners must not exceed the rated input shown on the rating plate. Overfiring of the furnace can result in premature heat exchanger failure. Gas pressures in excess of 13" W.C. can also cause permanent damage to the gas control valve.

At all altitudes, the manifold pressure must be within 0.3" W.C. of that listed in the Specification Sheet applicable to your model for the fuel used. At all altitudes and with either fuel, the air temperature rise must be within the range listed on the furnace nameplate.

Should this appliance be converted to LP gas, refer to the instructions included in the factory-authorized LP gas conversion kit.

High Altitude Derate

NOTE: The furnace will naturally derate itself with altitude. Do not attempt to increase the firing rate by changing orifices or increasing the manifold pressure. This can cause poor combustion and equipment failure.

High altitude installations may require both a pressure switch and an orifice change. These changes are necessary to compensate for the natural reduction in the density of both the gas fuel and the combustion air at higher altitude.

For installations above 7,000 ft (2,133.6 m), please refer to your distributor for the required kit(s).

Gas	Altitude	Kit	Orifice	Manifold Pressure		Pressure Switch Change
				High Stage	Low Stage	
Natural	0 to 7,000 ft	None	#43	3.5" W.C.	1.9" W.C.	None
Propane	(2,133.6 m)	LPM-05* LPM-06*	#55	10.0" W.C.	6.0" W.C.	None

NOTES:

- LPM-05* supports White-Rodgers 2-stage valve only.
- LPM-06* supports both Honeywell and White-Rodgers 2-stage valves.
- In Canada, gas furnaces are only certified to 4,500 ft (1,371.6 m).
- Contact the distributor for a tabular listing of appropriate manufacturer's kits for propane gas and/or high altitude installations. The indicated kits must be used to ensure safe and proper furnace operation. All conversions must be performed by a qualified installer or service agency.

Propane Gas Conversion

WARNING

Possible property damage, personal injury or death may occur if the correct conversion kits are not installed. The appropriate kits must be applied to ensure safe and proper furnace operation. All conversions must be performed by a qualified installer or service agency.

This furnace is configured for Natural gas. The appropriate manufacturer's propane gas conversion kit, must be applied for propane gas installations. Refer to "Propane Gas and/or High Altitude Installations" section for details.

Contact your distributor for a tabular listing of appropriate manufacturer's kits for propane gas and/or high altitude installations. The indicated kits must be used to ensure safe and proper furnace operation. All conversions must be performed by a qualified installer or service agency.

Gas Piping Connections

CAUTION

To avoid possible unsatisfactory operation or equipment damage due to underfiring of equipment, use the proper size of Natural/propane gas pipe needed when running pipe from the meter/tank to the furnace.

When sizing a trunk line, be sure to include all appliances which will operate simultaneously.

The gas piping supplying the furnace must be properly sized based on the gas flow required, specific gravity of the gas and the length of the run. The gas line installation must comply with local codes, or in their absence, with the latest edition of the National Fuel Gas Code, NFPA 54/ANSI Z223.1.

Natural Gas Capacity of Pipe—Cu ft of Gas Per Hour (CFH)

Length of Pipe—ft (m)	Nominal Black Pipe Size				
	½"	¾"	1"	1¼"	1½"
10 (3)	132	278	520	1,050	1,600
20 (6.1)	92	190	350	730	1,100
30 (9.2)	73	152	285	590	980
40 (12.2)	63	130	245	500	760
50 (15.2)	56	115	215	440	670
60 (18.3)	50	105	195	400	610
70 (21.3)	46	96	180	370	560
80 (24.4)	43	90	170	350	530
90 (27.4)	40	84	160	320	490
100 (30.5)	38	79	150	305	460

Pressure 0.5 psig or less and pressure drop of 0.3" W.C.; based on 0.60 specific gravity gas

$$CFH = \frac{\text{Btu/h Furnace Input}}{\text{Heating Value of Gas (Btu/cu ft)}}$$

To connect the furnace to the building's gas piping, the installer must supply a ground joint union, drip leg, manual shutoff valve and line and fittings to connect to the gas control valve. In some cases, the installer may also need to supply a transition piece from ½" (1.3 cm) pipe to a larger pipe size.

The following stipulations apply when connecting gas piping.

- Use black iron or steel pipe and fittings for building piping.
- Use pipe joint compound (pipe dope) on male threads only.
- Always use pipe joint compound (pipe dope) that is approved for all gases.

NOTE: Do not apply compound to the first 2 threads.

- Use ground joint unions.
- Install a drip leg to trap dirt and moisture before it can enter the gas control valve.

NOTE: The drip leg must be a minimum of 3" (7.6 cm) long.

- Install a ⅛" NPT pipe plug fitting, accessible for test gage connection, immediately upstream of the gas supply connection to the furnace.

- Use 2 pipe wrenches when making the connection to the gas control valve to keep it from turning.

NOTE: The orientation of the gas control valve on the manifold must be maintained as shipped from the factory.

- Install a manual shutoff valve between the gas meter and the furnace within 6 ft (1.8 m) of the furnace.
- If a union is installed, the union must be downstream of the manual shutoff valve, between the shutoff valve and the furnace.
- Tighten all joints securely.
- Connect the furnace to the building piping by one of the following methods:

1. Rigid metallic pipe and fittings.
2. Semirigid metallic tubing and metallic fittings.

NOTE: Aluminum alloy tubing must not be used in exterior locations.

- Use UL Listed/CSA approved gas appliance connectors in accordance with their instructions.
- Gas connectors must be fully in the same room as the furnace.
- Protect gas connectors and semirigid tubing against physical and thermal damage when installed.
- Ensure that aluminum alloy tubing and connectors are coated to protect against external corrosion when in contact with masonry, plaster, insulation or subjected to repeated wetting by liquids such as water (except rain water), detergents or sewage.

General Furnace Layout

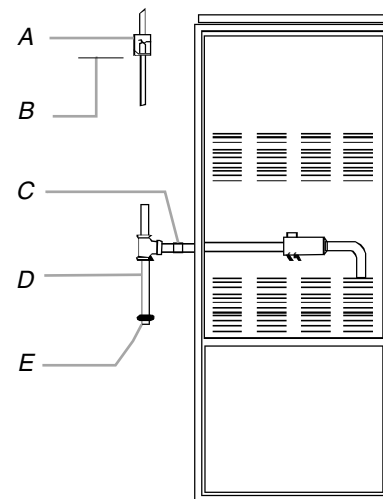

- A. Manual shutoff valve location (upstream of ground joint pipe union)
- B. Height required by local codes
- C. Ground joint pipe union (upstream of gas control valve)
- D. Drip leg
- E. Reducing coupling—½" x ⅛" with ⅛" pipe plug to measure line gas pressure

Upflow Installations

When the gas piping enters through the right side of the furnace, the installer must supply the following fittings (starting from the gas control valve):

- 90° elbows (2)
- Close nipple
- Straight pipe to reach the exterior of the furnace
- Ground joint union

Propane Gas Tanks and Piping

- Drip leg
- Manual shutoff valve
- Transition piece from 1/2" to another pipe size, if needed

When the gas piping enters through the left side of the furnace, the installer must supply the following fittings (starting from the gas control valve):

- Straight pipe to reach the exterior of the furnace
- Ground joint union
- Drip leg
- Manual shutoff valve
- Transition piece from 1/2" to another pipe size, if needed

Counterflow Installations

When the gas piping enters through the left side of the furnace, the installer must supply the following fittings (starting from the gas control valve):

- Straight pipe to reach the exterior of the furnace
- Ground joint union
- Drip leg
- Manual shutoff valve
- Transition piece from 1/2" to another pipe size, if needed

When the gas piping enters through the right side of the furnace, the installer must supply the following fittings (starting from the gas control valve):

- 90° elbows (2)
- Close nipple
- Straight pipe to reach the exterior of the furnace

Gas Piping Checks

Before placing the furnace in operation, leak test the furnace and gas connections.

WARNING

To avoid the possibility of explosion or fire, never use a match or open flame to test for leaks.

Check for leaks using an approved chloride-free soap and water solution, an electronic combustible gas detector, or other approved testing methods.

WARNING

To prevent property damage or personal injury due to fire, the following instructions must be performed regarding gas connections, pressure testing, location of shutoff valve and installation of gas piping.

NOTES:

- Never exceed specified pressures for testing. Higher pressure may damage the gas control valve and cause subsequent overfiring, resulting in heat exchanger failure.
- Disconnect this unit and external manual shutoff valve from the gas supply piping system before pressure testing the supply piping system with pressures in excess of 1/2 psig (3.48 kPa).
- Isolate this unit from the gas supply piping system by closing the external manual shutoff valve before pressure testing supply piping system with test pressures equal to or less than 1/2 psig (3.48 kPa).

WARNING

If the gas furnace is installed in a basement, and excavated area or a confined space, it is strongly recommended to contact a propane supplier to install a gas detecting warning device in case of a gas leak.
— Since propane gas is heavier than air, any leaking can settle in low areas or confined spaces.
— Propane gas odorant may fade, making the gas undetectable except with a warning device.

A gas detecting warning system is the only reliable way to detect a propane gas leak. Rust can reduce the level of odorant in propane gas. Do not rely on your sense of smell. Contact a local propane gas supplier about installing a gas detecting warning system.

NOTE: If a gas odor is detected, follow the instructions in "Gas Furnace Safety Precautions" in this manual.

All propane gas equipment must conform to the safety standards of the National Board of Fire Underwriters, NBFU Manual 58.

For satisfactory operation, propane gas pressure must be 10.0" W.C. at the furnace manifold with all gas appliances in operation.

Maintaining proper gas pressure depends on 3 main factors:

- Vaporization rate, depending on temperature of the liquid and "wetted surface" area of the container or containers.
- Proper pressure regulation. 2-stage regulation is recommended for both cost and efficiency.
- Pressure drop in the lines between the regulators, and between 2nd stage regulator and the appliance. Pipe size will depend on the length of the pipe run and the total load of all appliances.

Complete information regarding tank sizing for vaporization, recommended regulator settings, and pipe sizing is available from most regulator manufacturers and propane gas suppliers.

Since propane gas will quickly dissolve white lead and most standard commercial compounds, special pipe dope must be used. Shellac-based compounds resistant to the actions of liquefied petroleum gases, such as Gasolac®, Stalactic®, Clyde's® or John Crane® are satisfactory.

Refer to "Propane Gas Installation—Typical" for typical propane gas installations and piping.

Propane Gas Installation—Typical

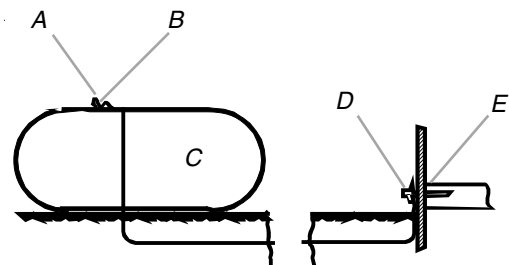

A. 1st stage regulator
B. 5 to 15 psig (20 psig maximum)
C. 200 psig maximum

D. 2nd stage regulator
E. Continuous 11.0" W.C.

Sizing Between 1st and 2nd Stage Regulator*

Maximum propane capacities listed are based on 2 psig pressure drop at 10 psig setting. Capacities in 1,000 Btu/h.

Propane Gas Piping Chart I

Pipe or Tubing Length—ft (m)	Tubing Size, O.D. Type L					Nominal Pipe Size Schedule 40	
	3/8"	1/2"	5/8"	3/4"	7/8"	1/2"	3/4"
10 (3)	730	1,700	3,200	5,300	8,300	3,200	7,500
20 (6.1)	500	1,100	2,200	3,700	5,800	2,200	4,200
30 (9.2)	400	920	2,000	2,900	4,700	1,800	4,000
40 (12.2)	370	850	1,700	2,700	4,100	1,600	3,700
50 (15.2)	330	770	1,500	2,400	3,700	1,500	3,400
60 (18.3)	300	700	1,300	2,200	3,300	1,300	3,100
80 (24.4)	260	610	1,200	1,900	2,900	1,200	2,600
100 (30.5)	220	540	1,000	1,700	2,600	1,000	2,300
125 (38.1)	200	490	900	1,400	2,300	900	2,100
150 (45.7)	190	430	830	1,300	2,100	830	1,900
175 (53.3)	170	400	780	1,200	1,900	770	1,700
200 (61)	160	380	730	1,100	1,800	720	1,500

To convert to capacities at 15 psig settings—multiply by 1.13. To convert to capacities at 5 psig settings—multiply by 0.879.

Sizing Between 2nd Stage and Appliance Regulator*

Maximum Propane Capacities Listed are Based on 2 psig pressure drop at 10.0" W.C. setting. Capacities in 1,000 Btu/h.

Propane Gas Piping Chart II

Pipe or Tubing Length—ft (m)	Tubing Size, O.D. Type L					Nominal Pipe Size Schedule 40					
	3/8"	1/2"	5/8"	3/4"	7/8"	1 1/8"	1/2"	3/4"	1"	1 1/4"	1 1/2"
10 (3)	39	92	199	329	501	935	275	567	1,071	2,205	3,307
20 (6.1)	26	62	131	216	346	630	189	393	732	1,496	2,299
30 (9.2)	21	50	107	181	277	500	152	315	590	1,212	1,858
40 (12.2)	19	41	90	145	233	427	129	267	504	1,039	1,559
50 (15.2)	18	37	79	131	198	376	114	237	448	913	1,417
60 (18.3)	16	35	72	121	187	340	103	217	409	834	1,275
80 (24.4)	13	29	62	104	155	289	89	185	346	724	1,066
100 (30.5)	11	26	55	90	138	255	78	162	307	630	976
125 (38.1)	10	24	48	81	122	224	69	146	275	567	866
150 (45.7)	9	21	43	72	109	202	63	132	252	511	787
200 (61)	8	19	39	66	100	187	54	112	209	439	665
250 (76.2)	8	17	36	60	93	172	48	100	185	390	590

Data in accordance with NFPA pamphlet Number 54.

CIRCULATING AIR AND FILTERS

Ductwork—Airflow

WARNING

Never allow the products of combustion, including carbon monoxide, to enter the return ductwork or circulation air supply.

- Duct systems and register sizes must be properly designed for the CFM and external static pressure rating of the furnace. Design the ductwork in accordance with the recommended methods of “Air Conditioning Contractors of America” Manual D.
- Install the duct system in accordance with Standards of the National Board of Fire Underwriters for the Installation of Air Conditioning, Warm Air Heating and Ventilating Systems. Pamphlets No. 90A and 90B.
- A closed return duct system must be used with the return duct connected to the furnace.
NOTE: Ductwork must never be attached to the back of the furnace.
- For installations requiring more than 1,800 CFM, use either 2 side returns or bottom return.
- Flexible joints may be used for supply and return connections to reduce noise transmission.
- To prevent the blower from interfering with combustion air or draft when a central return is used, a connecting duct must be installed between the unit and the utility room wall.
- Never use a room, closet or alcove as a return air chamber.
- The furnace is shipped with the top flanges in the flat position. Before installing a coil or ducts, the flanges must be bent 90 degrees.

When the furnace is installed with a cooling unit, the furnace should be installed in parallel with or on the upstream side of the cooling unit to avoid condensation in the heating element. With a parallel flow arrangement, the dampers or other means used to control the flow of air must be adequate to prevent chilled air from entering the furnace and, if manually operated, must be equipped with means to prevent operation of either unit unless the damper is in the full heat or cool position.

When the furnace is installed without a cooling unit, it is recommended that a removable access panel be provided in the outlet air duct. This opening shall be accessible when the furnace is installed and shall be of such a size that the heat exchanger can be viewed for visual light inspection or such that a sampling probe can be inserted into the airstream. The access panel must be made to prevent air leaks when the furnace is in operation.

NOTE: In a horizontal installation, the air conditioning coil must be adequately supported by proper brackets and supports. Inadequate coil support can result in furnace cabinet distortion and air leakage.

When the furnace is heating, the temperature of the return air entering the furnace must be between 55°F and 100°F (13°C and 38°C).

When a furnace is installed so that supply ducts carry air circulated by the furnace to areas outside the space containing the furnace, the return air shall also be handled by a duct sealed to the furnace casing and terminating outside the space containing the furnace.

Filters—Read this Section Before Installing the Return Air Ductwork

Filters must be used with this furnace. Discuss filter maintenance with the building owner. Filters are not ship with this furnace, but must be provided by the installer. Filters must comply with UL900 or CAN/ULCS111 standards. If the furnace is installed without filters, the warranty will be voided.

NOTE: An undersized opening will cause reduced airflow. The bottom return is set up as a knockout.

Upright Installations

Depending on the installation and/or customer preference, differing filter arrangements can be applied. Filters can be installed in the central return register, in a side panel external filter rack kit (upflows) or in the ductwork above a downflow furnace. As an alternative, a media air filter or electronic air cleaner can be used as the primary filter.

Circulation Air Filters

One of the most common causes of a problem in a forced air heating system is a blocked or dirty filter. Circulating air filters must be inspected monthly for dirt accumulation and replaced if necessary. Failure to maintain clean filters can cause premature heat exchanger failure.

A new home may require more frequent replacement until all construction dust and dirt is removed. Circulating air filters are to be installed in the return air duct external to the furnace cabinet.

Minimum Filter Sizes for Disposable Filters—Disposable Nominal 300 F.M. Face Velocity

Furnace Input	Filter Size (sq. in.)
70M	768
90M	960
115M	1,022

Horizontal Installations

Filters must be installed in either the central return register or in the return air ductwork.

START-UP PROCEDURE AND ADJUSTMENT

This furnace must have a 115 VAC power supply properly connected and grounded. Proper polarity must be maintained for correct operation. In addition to the following start-up and adjustment items, refer to further information in "Operational Checks."

Heat Anticipator Setting

The heat anticipator in the room thermostat must be correctly adjusted to obtain the proper number of cycles per hour and to avoid "overshooting" of the setting. Set the heat anticipator setting to 0.7 amps. Follow the thermostat manufacturer's instructions on how to adjust the heat anticipator setting.

Furnace Operation

1. Purge the gas lines of air prior to start-up.
NOTE: Be sure not to purge lines into an enclosed burner compartment.
2. Check for leaks using an approved chloride-free soap and water solution, an electronic combustible gas detector or other approved method.
3. Verify that all required kits (propane gas, high altitude, etc.) have been appropriately installed.

Furnace Start-Up

1. Close the manual gas shutoff valve external to the furnace.
 2. Turn off the electrical power to the furnace.
 3. Set the room thermostat to the lowest possible setting.
 4. Remove the burner compartment door.
- NOTE:** This furnace is equipped with an ignition device which automatically lights the burner. Do not try to light the burner by hand.
5. Move the furnace gas control valve manual control to the Off position.
 6. Wait 5 minutes, and then check for a gas odor.
NOTE: Check near the floor since some types of gas are heavier than air.
 7. If a gas odor is detected, follow the instructions in "Gas Furnace Safety Precautions" in this manual.
 8. If no gas odor is detected, move the furnace gas control valve manual control to the On position.
 9. Replace the burner compartment door.
 10. Open the manual gas shutoff valve external to the furnace.
 11. Turn on the electrical power to the furnace.
 12. Adjust the thermostat to a setting above room temperature.
 13. After the burners are lit, set the thermostat to the desired temperature.

Furnace Shutdown

1. Set the thermostat to the lowest setting.
The integrated control will close the gas control valve and extinguish the flame. Following a 15-second delay, the induced draft blower will be de-energized. After a 120-, 150-, 180- or 210-second delay period (field-selectable delay Off [90, 120, 150, 180] plus a 30-second ramp down), the circulator blower de-energizes.

2. Remove the burner compartment door and move the furnace gas control valve manual control to the Off position.
3. Close the manual gas shutoff valve external to the furnace.
4. Replace the burner compartment door.

Gas Supply Pressure Measurement

CAUTION

To prevent unreliable operation or equipment damage, the inlet gas supply pressure must be as specified on the unit rating plate with all other household gas-fired appliances operating.

The line pressure supplied to the gas control valve must be within the range specified below. The supply pressure can be measured at the gas control valve inlet pressure boss or at a hose fitting installed in the gas piping drip leg. The supply pressure must be measured with the burners operating. To measure the gas supply pressure, use the following procedure.

Gas Control Valve—White-Rodgers 2-Stage 36G54

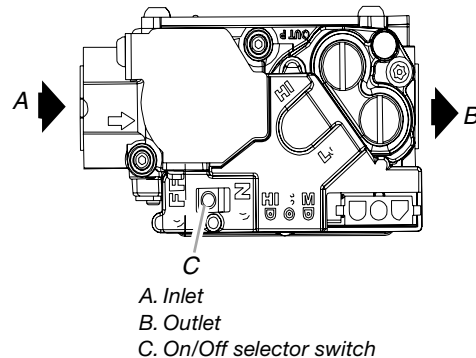

Gas Control Valve—White-Rodgers 36G54 Connected to Manometer

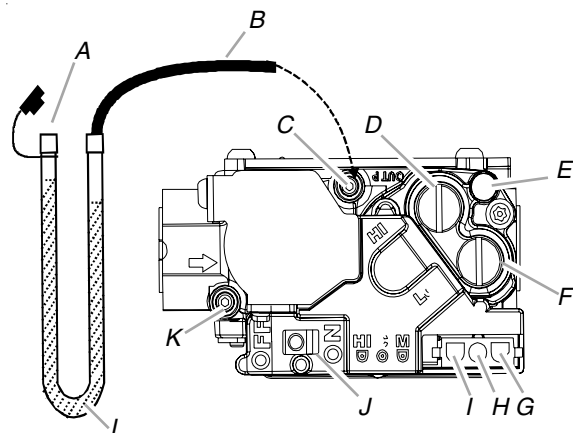

- | | |
|-------------------------------|---------------------------------|
| A. Open to atmosphere | G. Coaxial coil terminal (M) |
| B. Manometer hose | H. Common terminal (C) |
| C. Outlet pressure boss | I. High-fire coil terminal (HI) |
| D. High-fire regulator adjust | J. On/Off selector switch |
| E. Regulator vent | K. Inlet pressure boss |
| F. Low-fire regulator adjust | L. Manometer |

Gas Control Valve—Honeywell 2-Stage VR9205

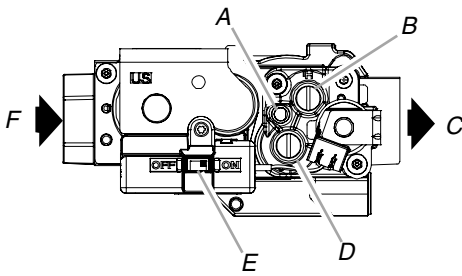

- A. Regulator vent
 B. High-fire regulator adjust
 C. Outlet
 D. Low-fire regulator adjust
 E. On/Off selector switch
 F. Inlet

Gas Control Valve—Honeywell VR9205 Connected to Manometer

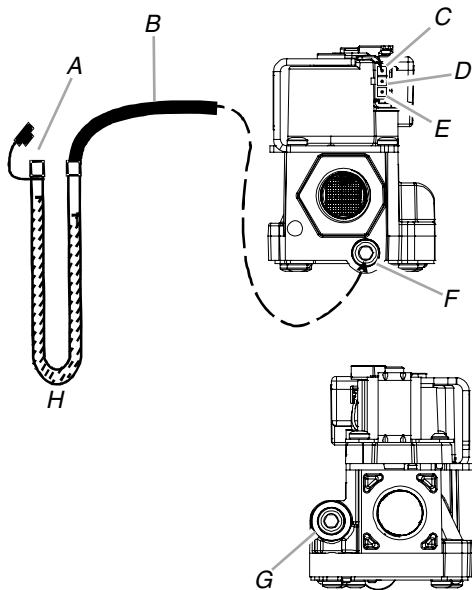

- A. Open to atmosphere
 B. Manometer hose
 C. Common terminal (C)
 D. High-fire coil terminal (HI)
 E. Low-fire coil terminal (LO)
 F. 1/8" NPT inlet pressure tap
 G. 1/8" NPT outlet pressure tap
 H. Manometer

1. Turn off the gas supply to the furnace at the manual gas shutoff valve external to the furnace.
2. Disconnect all electrical power to the system.
3. Connect a calibrated water manometer (or appropriate gas pressure gauge) at either the gas control valve inlet pressure boss or the gas piping drip leg. See "Gas Control Valve—Honeywell VR9205 Connected to Manometer" or "Gas Control Valve—White-Rodgers 36G54 Connected to Manometer" illustration for location of inlet pressure boss/tap.

NOTE: If you are measuring the gas pressure at the drip leg or on the Honeywell VR9205 gas control valve, a field-supplied hose barb fitting must be installed prior to making the hose connection. If using the inlet pressure boss on the White-Rodgers 36G54 gas control valve, then use the 36G Valve Pressure Check Kit, Part Number 0151K00000S.

4. Turn on the gas supply and operate the furnace and all other gas consuming appliances on the same gas supply line.

5. Measure the furnace gas supply pressure with burners firing.

NOTE: Supply pressure must be within the range specified in the Inlet Gas Supply Pressure chart.

Inlet Gas Supply Pressure

Natural Gas	Minimum: 5.0" W.C. Maximum: 10.0" W.C.
Propane Gas	Minimum: 11.0" W.C. Maximum: 13.0" W.C.

If the supply pressure differs from chart, make the necessary adjustments to the pressure regulator, gas piping size, etc., and/or consult with local gas utility.

6. Turn off the gas supply to the furnace at the manual shutoff valve.
7. Disconnect the manometer.
8. Reinstall plug before turning on gas supply to furnace.
9. Turn off any unnecessary gas appliances that were turned on in Step 4.

Measuring Inlet Gas Pressure—Alternate Method

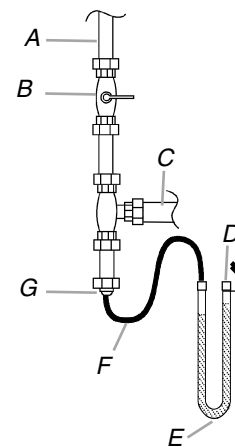

- A. Gas supply line
 B. Gas shutoff valve
 C. Gas supply line to furnace
 D. Open to atmosphere
 E. Manometer
 F. Manometer hose
 G. Dripleg cap with fitting

Gas Manifold Pressure Measurement and Adjustment

CAUTION

To prevent unreliable operation or equipment damage, the gas manifold pressure must be as specified on the unit rating plate. Only minor adjustments should be made by adjusting the gas control valve pressure regulator.

Only small variations in gas pressure should be made by adjusting the gas control valve pressure regulator. The manifold pressure must be measured with the burners operating. To measure and adjust the manifold pressure, use the following procedure.

1. Turn off the gas supply to furnace at the manual gas shutoff valve external to the furnace.
2. Turn off all electrical power to the system.

3. Outlet pressure tap connections:
 - Honeywell VR9205 valve: Remove the outlet pressure boss plug. Install an 1/8" NPT hose barb fitting into the outlet pressure tap.
 - White-Rodgers 36G54 valve: Back outlet pressure test screw (inlet/outlet pressure boss) out one turn counterclockwise (not more than one turn).
4. Attach a hose and manometer to the outlet pressure barb fitting (Honeywell valve) or outlet pressure boss (White-Rodgers valve).
5. Turn on the gas supply.
6. Turn on power and close thermostat R and W1 contacts to provide a call for low-stage heat.
7. Measure the gas manifold pressure with burners firing.
8. Adjust manifold pressure using the Manifold Gas Pressure chart shown below.
9. Remove the regulator cover screw from the low (LO) outlet pressure regulator adjust tower.
10. Turn the screw clockwise to increase pressure or counterclockwise to decrease pressure.
11. Replace regulator cover screw.
12. Close thermostat R and W2 contacts to provide a call for high-stage heat.
13. Remove the regulator cover screw from the high (HI) outlet pressure regulator adjust tower.
14. Turn the screw clockwise to increase pressure or counterclockwise to decrease pressure.
15. Replace the regulator cover screw.
16. Turn off all electrical power and gas supply to the system.
17. Remove the manometer hose from the hose barb fitting or outlet pressure boss.
18. Replace the outlet pressure tap:
 - Honeywell VR9205 valve: Remove the 1/8" NPT hose barb fitting from the outlet pressure tap. Replace the outlet pressure boss plug and seal with a high quality thread sealer.
 - White-Rodgers 36G54 valve: Turn the outlet pressure test screw in to seal pressure port (clockwise, 7 in.-lb minimum).
19. Turn on electrical power and gas supply to the system.
20. Close the thermostat contacts R and W1/W2 to energize the valve.
21. Using a leak detection solution or soap suds, check for leaks at the outlet pressure boss plug (Honeywell valve) or screw (White-Rodgers valve). Bubbles forming indicate a leak.

IMPORTANT: If a leak is detected, turn off gas immediately and repair all leaks.

NOTE: For gas-to-gas conversion, consult your dealer for appropriate conversion.

Manifold Gas Pressure

Gas		Range	Nominal
Natural	Low Stage	1.6" to 2.2" W.C.	1.9" W.C.
	High Stage	3.2" to 3.8" W.C.	3.5" W.C.
Propane	Low Stage	5.7" to 6.3" W.C.	6.0" W.C.
	High Stage	9.7" to 10.3" W.C.	10.0" W.C.

Gas Input Rate Measurement—Natural Gas Only

The gas input rate to the furnace must never be greater than that specified on the unit rating plate. To measure Natural gas input using the gas meter, use the following procedure.

1. Turn off the gas supply to all other gas-burning appliances except the furnace.
2. While the furnace is operating, time and record one complete revolution of the smallest gas meter dial.
3. Calculate the number of seconds per cubic foot (sec/ft³) of gas being delivered to the furnace. If the dial is a 1 cubic foot dial, divide the number of seconds recorded in Step 2 by 1. If the dial is a 2 cubic foot dial, divide the number of seconds recorded in Step 2 by 2.
4. Calculate the furnace input in Btu per hour (Btu/h). Input equals the sum of the installation's gas heating value and a conversion factor (hours to seconds) divided by the number of seconds per cubic foot. The measured input must not be greater than the input indicated on the unit rating plate.

Example: Installation's gas heating (HTG) value: 1,000 Btu/ft³ (Obtained from gas supplier)

Installation's seconds per cubic foot: 34 sec/ft³

Conversion Factor (hours to seconds): 3,600 sec/h

Input = (Htg. value x 3,600) ÷ seconds per cubic foot

Input = (1,000 Btu/ft³ x 3,600 sec/h) ÷ 34 sec/ft³

Input = 106,000 Btu/h

Minor changes to the input rate may be accomplished through manifold pressure adjustments at the gas control valve. Refer to "Gas Manifold Pressure Measurement and Adjustment" section for details.

NOTE: The final manifold pressure cannot vary by more than ± 0.3" W.C. from the specified setting. Consult your local gas supplier if additional input rate adjustment is required.

5. Repeat steps 2 through 4 on high stage.
6. Turn on the gas supply to all other appliances turned off in Step 1.
7. Ensure that all appliances are functioning properly and that all pilot burners are lit and operating.

Temperature Rise

Temperature rise must be within the range specified on the unit rating plate. An incorrect temperature rise may result in condensing in or overheating of the heat exchanger. An airflow and temperature rise table is provided in the Specification Sheet applicable to your model. Determine and adjust temperature rise as follows:

1. Operate furnace with burners firing for approximately 10 minutes.
2. Ensure that all registers are open and all duct dampers are in their final (fully or partially open) position.
3. Place thermometers in the return and supply ducts as close to the furnace as possible. Thermometers must not be influenced by radiant heat from the heat exchanger.

Temperature Rise Measurement

Rise = Supply air temperature - Return air temperature

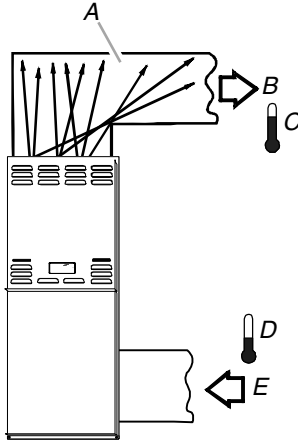

A. Heat exchanger radiation "line of sight"
 B. Supply air
 C. Supply air temperature
 D. Return air temperature
 E. Return air

- Subtract the return air temperature from the supply air temperature to determine the air temperature rise. Allow adequate time for thermometer readings to stabilize.
- Adjust the temperature rise by adjusting the circulator blower speed. Increase blower speed to reduce temperature rise. Decrease blower speed to increase temperature rise. Refer to "Circulator Blower Speeds" for speed changing details.

Circulator Blower Speeds

WARNING

To avoid personal injury or death due to electrical shock, turn OFF power to the furnace before changing speed taps.

This furnace is equipped with a multispeed circulator blower. This blower provides ease in adjusting blower speeds. The Specification Sheet applicable to your model provides an airflow table, showing the relationship between airflow (CFM) and external static pressure (E.S.P.), for the proper selection of heating and cooling speeds. The heating blower speed is shipped set at B, and the cooling blower speed is set at D. These blower speeds should be adjusted by the installer to match the installation requirements so as to provide the correct heating temperature rise and correct cooling CFM.

Use the dual 7-segment LED display adjacent to the DIP switches to obtain the approximate airflow quantity. The airflow quantity is displayed as a number on the display, rounded to the nearest 100 CFM. The display alternates airflow delivery indication and the operating mode indication.

Example: The airflow being delivered is 1,225 CFM. The display indicates 12. If the airflow being delivered is 1,275, the display indicates 13.

- Determine the tonnage of the cooling system installed with the furnace. If the cooling capacity is in Btu/h, divide it by 12,000 to convert capacity to Tons.

Example: Cooling Capacity of 30,000 Btu/h
 $30,000/12,000 = 2.5$ Tons

- Determine the proper airflow for the cooling system. Most cooling systems are designed to work with airflows between 350 and 450 CFM per ton. Most manufacturers recommend an airflow of about 400 CFM per ton.

Example: 2.5 tons X 400 CFM per ton = 1,000 CFM

NOTE: The cooling system manufacturer's instructions must be checked for required airflow. Any electronic air cleaners or other devices may require specific airflows, consult installation instructions of those devices for requirements.

- Knowing the furnace model, locate the high-stage cooling airflow charts in the Specification Sheet applicable to your model. Look up the cooling airflow determined in Step 2 and find the required cooling speed and adjustment setting.

Example: A WGFM28070V4BX furnace installed with a 2.5 ton air conditioning system. The airflow needed is 1,000 CFM. Looking at the cooling speed chart for WGFM28070V4BX, find the airflow closest to 1,000 CFM. A cooling airflow of 990 CFM can be attained by setting the cooling speed to C and the adjustment to "-" (minus).

- Continuous fan speed is 30% of the furnace's maximum airflow capability.

Example: If the furnace's maximum airflow capability is 2,000 CFM, the continuous fan speed will be $0.30 \times 2,000 \text{ CFM} = 600 \text{ CFM}$.

- Locate the blower speed selection DIP switches on the integrated control module. Select the desired cooling speed tap by positioning DIP switches 1 and 2 appropriately.

Select the desired adjust tap by positioning DIP switches 3 and 4 appropriately. Refer to the following charts for DIP switch positions and their corresponding taps. Verify CFM by noting the number displayed on the dual 7-segment LED display.

Speed Selection DIP Switches

Tap	Cool Selection Switches		Adjust Selection Switches		Profile Selection Switches		Heat Selection Switches	
	1	2	3	4	5	6	7	8
A	Off	Off	Off	Off	Off	Off	Off	Off
B	On	Off	On	Off	On	Off	On	Off
C	Off	On	Off	On	Off	On	Off	On
D	On	On	On	On	On	On	On	On

Switch Bank: S3

Cooling Tap	DIP Switch Number	
	1	2
A	Off	Off
B	On	Off
C	Off	On
D*	On	On

*Indicates factory setting

Speed Taps—Adjust

Switch Bank: S3

Adjust Tap	DIP Switch Number	
	3	4
Normal*	Off	Off
+10% Adjust	On	Off
-10% Adjust	Off	On
Normal	On	On

*Indicates factory setting

Comfort Mode Profiles

The multispeed circulator blower also offers several custom On/Off ramping profiles. These profiles may be used to enhance the cooling performance and increase the comfort level. The ramping profiles are selected using DIP switches 5 and 6. See the “Profile” illustrations for DIP switch positions and their corresponding taps. Verify CFM by noting the number displayed on the dual 7-segment LED display.

Ramping Profile Tap	DIP Switch Number	
	5	6
A*	Off	Off
B	On	Off
C	Off	On
D	On	On

*Indicates factory setting

Profile A

- Provides a 1-minute Off delay at 100% of the cooling demand airflow.

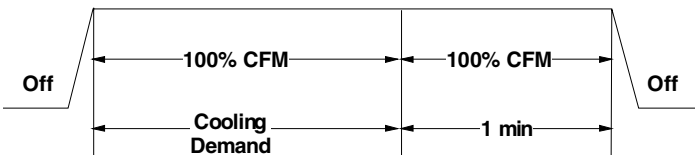

Profile B

- Ramps up to 50% of the full cooling demand airflow for 30 seconds.
- The motor then ramps to 100% of the required airflow.
- Provides a 1-minute Off delay at 100% of the cooling demand airflow.

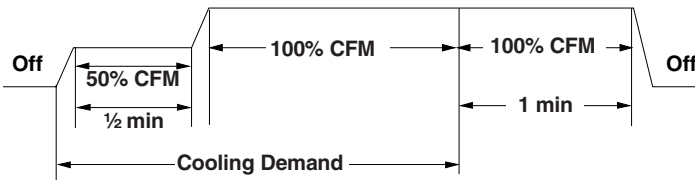

Profile C

- Ramps up to 85% of the full cooling demand airflow for approximately 7½ minutes.
- The motor then ramps to 100% of the required airflow.

- Provides a 1-minute Off delay at 100% of the cooling demand airflow.

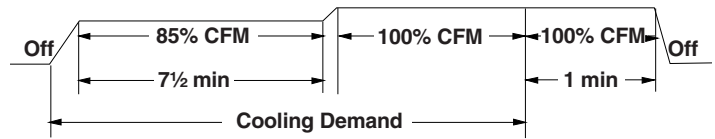

Profile D

- Ramps up to 50% of the full cooling demand airflow for 30 seconds.
- Then ramps to 85% of the full cooling demand airflow for approximately 7½ minutes.
- The motor then ramps to 100% of the required airflow.
- Provides a 30-second Off delay at 50% of the cooling demand airflow.

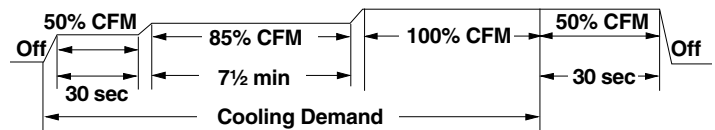

6. Select the heating speed from the heating speed chart in the Specification Sheet for your model. The Adjust Taps setting (already established by the cooling speed selection) determines which set of speeds are available. The selected speed must provide a temperature rise within the rise range listed with the particular model.

Example: The WGFM290508V4C is set for 990 CFM on cooling, the “ADJUST” is set to “+” (plus). The 4 heating speeds available are “A Plus,” “B Plus,” “C Plus” and “D Plus.” “A Plus” has a rise of 38°F for both stages which is within the 20°F to 50°F rise range for the WGFM290508V4C. This setting will keep electrical consumption to a minimum. Set the “Heat” speed DIP switches to “A.”

Switch Bank: S4

Heating Tap	DIP Switch Number	
	7	8
A	Off	Off
B*	On	Off
C	Off	On
D	On	On

*Indicates factory setting

7. Select the desired heating speed tap by positioning DIP switches 7 and 8 appropriately. Verify CFM by noting the number displayed on the dual 7-segment LED display.

In general, lower heating speeds will reduce electrical consumption, lower operating sound levels of the blower and increase the outlet air temperature delivered to the home. The speeds available allow the blower performance to be optimized for the particular homeowner’s needs.

Profiles	Pre-Run	Short-Run	Off -Delay
A	-	-	60 sec/100
B*	-	30 sec/50	60 sec/100
C	-	7.5 min/85	60 sec/100
D	30 sec/50	7.5 min/85	30 sec/50

*Indicates factory setting

To Set Airflow

1. Select the model and desired high-stage cooling airflow.
2. Determine the corresponding tap (A, B, C, or D).
3. Set DIP switches 1 and 2 to the appropriate On/Off positions.
4. Select the model and desired high-stage heating airflow.
5. Determine the corresponding tap (A, B, C, or D).
6. Set DIP switches 7 and 8 to the appropriate On/Off positions.
7. Select the airflow adjustment factor taps (A and D are 1; Tap B is +10; Tap C -10).
8. Set DIP switches 3 and 4 to the appropriate On/Off positions.

To Set Comfort Mode

1. Select desired comfort mode profile. See Comfort Mode Profile chart.
2. Set DIP switches 5 and 6 to the appropriate On/Off positions.

Model	Tap	Low-Stage Cool	High-Stage Cool	Low-Stage Heat	High-Stage Heat
WGFD28070V3BX	A	390	600	735	1,050
	B	520	800	805	1,150
	C	650	1,000	875	1,250
	D	780	1,200	935	1,350
WGFD28090V5CX	A	520	800	945	1,350
	B	715	1,100	1,015	1,450
	C	910	1,400	1,085	1,550
	D	1,170	1,800	1,155	1,650
WGFD28115V5CX	A	553	850	1,085	1,550
	B	748	1,150	1,155	1,650
	C	943	1,450	1,225	1,750
	D	1,203	1,850	1,260	1,800
WGFM28070V4BX	A	390	600	875	1,250
	B	520	800	945	1,350
	C	715	1,100	1,015	1,450
	D	910	1,400	1,085	1,550
WGFM28090V5CX	A	520	800	1,050	1,500
	B	715	1,100	1,120	1,600
	C	910	1,400	1,190	1,700
	D	1,170	1,800	1,260	1,800
WGFM28115V5CX	A	520	800	1,210	1,725
	B	715	1,100	1,225	1,750
	C	910	1,400	1,245	1,775
	D	1,170	1,800	1,260	1,800

Blower Heat Off Delay Timings

The integrated control module provides a selectable heat-off delay function. The heat off delay period may be set to 90, 120, 150 or 180 seconds using the DIP switches or jumper provided on the control module. The delay is factory-shipped at 150 seconds, but may be changed to suit the installation requirements and/or homeowner preference. Refer to the following chart for DIP switch positions and corresponding delay times.

Switch Bank: S1

Heat-Off Delay	DIP Switch Number	
	1	2
90 seconds	Off	Off
120 seconds	On	Off
150 seconds*	Off	On
180 seconds	On	On

*Indicates factory setting

NORMAL SEQUENCE OF OPERATION

Power Up

The normal power up sequence is as follows:

- 115 VAC power applied to furnace.
- Integrated control module performs internal checks.
- Integrated control module displays "88" on the dual 7-segment LED display.
- Integrated control module monitors safety circuits continuously.
- Furnace awaits call from thermostat. Displays "On" on the dual 7-segment LED display.

Heating Mode

The normal operational sequence in heating mode is as follows:

- R and W1 (or R and W1/W2) thermostat contacts close, initiating a call for heat.
- Integrated control module performs safety circuit checks.
- Induced draft blower is energized on high speed for a 15-second prepurge. Humidifier terminal is energized with induced draft blower.
- Induced draft blower steps to low speed following prepurge. Low-stage pressure switch contacts are closed.
- Igniter warm-up begins upon step to low speed and presence of closed low-stage pressure switch contacts.
- Gas control valve opens at the end of the igniter warm-up period, delivering gas to the burners and establishing a flame.
- Integrated control module monitors flame presence. Gas control valve will remain open only if flame is detected.

- If the thermostat call is for low heat, the gas control valve and induced draft blower will continue on low stage. If the call is for high heat, the gas control valve and induced draft blower will change to high stage.
- Circulator blower is energized on heat speed following a fixed 30-second blower-on delay. The circulator blower requires 30 seconds to ramp up to full speed. Electronic air cleaner terminal is energized with circulator blower.
- Furnace is now operating on the specified stage called for by the 2-stage thermostat.
- Furnace runs, integrated control module monitors safety circuits continuously.
- If the 2-stage thermostat changes the call from low heat to high heat, the integrated control module will immediately switch the induced draft blower, gas control valve and circulator blower to their high-stage settings.
- If the 2-stage thermostat changes the call from high heat to low heat, the integrated control module will immediately switch the induced draft blower and gas control valve to their low-stage settings. The circulator blower will remain on high-heating speed for 30 seconds before switching to the low-heat circulating speed.
- R and W1 (or R and W1/W2) thermostat contacts open, completing the call for heat.
- Gas control valve closes, extinguishing flame.
- Induced draft blower is de-energized following a 15-second post purge. Humidifier terminal is de-energized.
- Circulator blower continues running for the selected heat-off delay period (90, 120, 150 or 180 seconds). The speed run during this period depends on the last heat call provided by the thermostat. If the last call for heat was a call for low heat, the air circulator motor will run on low heat speed for the duration of the heat-off delay period (90, 120, 150 or 180 seconds). If the last call for heat was a call for high heat, the air circulating motor will run on the high heating speed for 30 seconds and then switch to the low-heating speed for the balance of the heat-off delay period (60, 90, 120 or 150 seconds).
- Circulator blower and electronic air cleaner terminals are de-energized.
- Circulator blower ramps down to Off during the 30 seconds following the heat-off delay period.
- Furnace awaits next call from thermostat.

Cooling Mode

The normal operational sequence in cooling mode is as follows:

- R and Y1/G or Y2/G thermostat contacts close, initiating a call for cool.
- Integrated control module performs safety circuit checks.
- Outdoor fan and compressor are energized to their appropriate speeds.
- Circulator blower is energized on the appropriate cool speed at the level and time determined by the selected ramping profile. Electronic air cleaner terminals are energized with circulator blower.
- Furnace circulator blower and outdoor cooling unit run their appropriate speed; Integrated control module monitors safety circuits continuously.
- R and Y1/G or Y2/G thermostat contacts open, completing the call for cool.
- Outdoor fan and compressor are de-energized.
- Circulator blower continues running during a cool-off delay period. The Off delay time and airflow level are determined by the selected ramping profile.

- Electronic air cleaner terminal and circulator blower are de-energized.
- Furnace awaits next call from thermostat.

Fan Only Mode

The normal operational sequence in fan only mode is as follows:

- R and G thermostat contacts close, initiating a call for fan.
- Integrated control module performs safety circuit checks.
- Circulator blower is energized on continuous fan speed (30% of the furnace's maximum airflow capability) following a 5-second delay. Electronic air cleaner terminal is energized.
- Circulator blower runs; integrated control module monitors safety circuits continuously.
- R and G thermostat contacts open, completing the call for fan.
- Electronic air cleaner terminal and circulator blower are de-energized.
- Furnace awaits next call from thermostat.

Operational Checks

Burner Flame

The burner flames should be inspected with the burner compartment door installed. Flames should be stable, soft and blue (dust may cause orange tips but must not be yellow). The flames must extend directly outward from the burner without curling, floating or lifting off. Flames must not impinge on the sides of the heat exchanger firing tubes.

Burner Flame

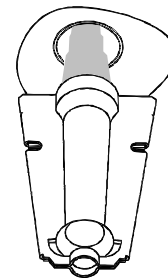

Check the burner flames for good adjustment, a stable, soft and blue flame that is not curling, floating or lifting off.

SAFETY CIRCUIT DESCRIPTION

General

A number of circuits are employed to ensure proper furnace operation. These circuits serve to control any potential safety hazards and serve as inputs in the monitoring and diagnosis of abnormal function. These circuits are continuously monitored during furnace operation by the integrated control module.

Integrated Control Module

The integrated control module is an electronic device which, if a potential safety concern is detected, will take the necessary precautions and provide diagnostic information through an LED.

Primary Limit Control

The primary limit control is located on the partition panel and monitors heat exchanger compartment temperatures. It is a normally closed (electrically), automatic reset, temperature-activated sensor. The limit guards against overheating as a result of insufficient conditioned air passing over the heat exchanger.

Auxiliary Limit Controls

The auxiliary limit controls are located on or near the circulator blower and monitors blower compartment temperatures. They are normally-closed (electrically), auto-reset sensors. These limits guard against overheating as a result of insufficient conditioned air passing over the heat exchanger.

Rollout Limit Controls

The rollout limit controls are mounted on the burner/manifold assembly and monitor the burner flame. They are normally-closed (electrically), manual-reset sensors. These limits guard against burner flames not being properly drawn into the heat exchanger.

Pressure Switches

The pressure switches are normally-open (closed during operation), negative air pressure-activated switches. They monitor the airflow (combustion air and flue products) through the heat exchanger via pressure taps located on the induced draft blower and the coil front cover. These switches guard against insufficient airflow (combustion air and flue products) through the heat exchanger and/or blocked condensate drain conditions.

Flame Sensor

The flame sensor is a probe mounted on the burner/manifold assembly which uses the principle of flame rectification to determine the presence or absence of flame.

MAINTENANCE

WARNING

HIGH VOLTAGE!
To avoid personal injury or death due to electrical shock, disconnect electrical power before performing any maintenance. If you must handle the igniter, handle with care. Touching the igniter element with bare fingers, rough handling or vibration could damage the igniter resulting in premature failure. Only a qualified servicer should ever handle the igniter.



Annual Inspection

The furnace should be inspected by a qualified installer, or service agency at least once per year. This check should be performed at the beginning of the heating season. This will ensure that all furnace components are in proper working order and that the heating system functions appropriately. Pay particular attention to the following items. Repair or service as necessary.

- Flue pipe system. Check for blockage and/or leakage. Check the outside termination and the connections at and internal to the furnace.
 - Heat exchanger. Check for corrosion and/or buildup within the heat exchanger passageways.
 - Burners. Check for proper ignition, burner flame and flame sense.
 - Drainage system. Check for blockage and/or leakage. Check hose connections at and internal to furnace.
 - Wiring. Check electrical connections for tightness and/or corrosion. Check wires for damage.
 - Filters.
-

Filters

CAUTION

To ensure proper unit performance, adhere to the filter sizes given in the Recommended Minimum Filter Size chart or Specification Sheet applicable to your model.

NOTE: Please contact your distributor or our website for the applicable Specification Sheet referred to in this manual.

Filter Maintenance

Improper filter maintenance is the most common cause of inadequate heating or cooling performance. Filters should be cleaned (permanent) or replaced (disposable) every 2 months or as required. When replacing a filter, it must be replaced with a filter of the same type and size.

Filter Removal

Depending on the installation, differing filter arrangements can be applied. Filters can be installed in either the central return register or a side panel external filter rack (upflow only).

A media air filter or electronic air cleaner can be used as an alternate filter. Follow the filter sizes given in the Recommended Minimum Filter Size chart to ensure proper unit performance.

To remove filters from an external filter rack in an upright upflow installation, follow the directions provided with external filter rack kit.

Horizontal Unit Filter Removal

Filters in horizontal installations are located in the central return register or the ductwork near the furnace.

To remove:

1. Turn off electrical power to the furnace.
 2. Remove the filter(s) from the central return register or ductwork.
 3. Replace the filter(s) by reversing the procedure for removal.
 4. Turn on electrical power to the furnace.
-

Media Air Filter or Electronic Air Cleaner Removal

Follow the manufacturer's directions for service.

Burners

WARNING

To avoid personal injury or death due to electrical shock, do not remove any internal compartment covers or attempt any adjustment. Contact a qualified servicer at once if an abnormal flame should develop.

Visually inspect the burner flames periodically during the heating season. Turn on the furnace at the thermostat and allow several minutes for flames to stabilize, since any dislodged dust will alter the flames normal appearance. Flames should be stable, quiet, soft and blue (dust may cause orange tips but they must not be yellow). They should extend directly outward from the burners without curling, floating or lifting off. Flames must not impinge on the sides of the heat exchanger firing tubes.

Induced Draft and Circulator Blowers

The bearings in the induced draft blower and circulator blower motors are permanently lubricated by the manufacturer. No further lubrication is required. Check motor windings for accumulation of dust which may cause overheating. Clean as necessary.

Condensate Trap and Drain System (Qualified Servicer Only)

Annually inspect the drain tubes, drain trap and field-supplied drain line for proper condensate drainage. Check drain system for hose connection tightness, blockage and leaks. Clean or repair as necessary.

Flame Sensor (Qualified Servicer Only)

Under some conditions, the fuel or air supply can create a nearly invisible coating on the flame sensor. This coating acts as an insulator causing a drop in the flame sense signal. If the flame sense signal drops too low, the furnace will not sense flame and will lock out. The flame sensor should be carefully cleaned by a qualified servicer using emery cloth or steel wool. Following cleaning, the flame sense signal should be as indicated in the Specifications Sheet.

Flue Passages (Qualified Servicer Only)

The heat exchanger flue passageways should be inspected at the beginning of each heating season. If necessary, clean the passageways as outlined below.

1. Turn off the electrical power and gas supply to the furnace.
2. Disconnect the gas line and remove the burner/manifold assembly by removing the screws securing the assembly to the partition panel.
3. Disconnect the flue pipe system from the induced draft blower.
4. Remove the induced draft blower and collector box cover.
5. Remove the recuperator coil front cover to expose the coil tubes and turbulators.

6. Remove the recuperator coil turbulators individually by slowly pulling each turbulator forward firmly.
7. Clean the recuperator coil tubes using a long handle wire brush, such as a gun cleaning brush.
8. Clean the primary heat exchanger tubes using a wire brush attached to a length of high grade stainless steel cable, such as drain cleanout cable. Attach a variable speed reversible drill to the other end of the cable. Slowly rotate the cable with the drill and insert it into one of the heat exchanger tubes. While reversing the drill, work the cable in and out several times to obtain sufficient cleaning. Repeat for each tube.
9. Clean the residue from the furnace by using a vacuum cleaner.
10. Replace the parts removed in the previous steps in reverse order.
11. Turn on electrical power and gas to furnace. Check for leaks and proper unit operation.
12. Severe heat exchanger fouling is an indication of an operational problem. Perform the checks listed in "Start-Up Procedure and Adjustments" to reduce the chances of repeated fouling.

Before Leaving an Installation

- Cycle the furnace with the thermostat at least 3 times. Verify cooling and fan only operation.
- Review the Owner's Manual with the homeowner and discuss proper furnace operation and maintenance.
- Leave literature packet near furnace.

Repair and Replacement Parts

When ordering any of the listed functional parts, be sure to provide the furnace model, manufacturing and serial numbers with the order.

Although only functional parts are shown in the parts list, all sheet metal parts, doors, etc., may be ordered by description.

Parts are available from your distributor.

Functional Parts List

■ Gas Control Valve	■ Blower Motor
■ Gas Manifold	■ Blower Wheel
■ Natural Gas Orifice	■ Blower Mounting Bracket
■ Propane Gas Orifice	■ Blower Cutoff
■ Igniter	■ Blower Housing
■ Flame sensor	■ Inductor
■ Rollout Limit Switch	■ Heat Exchanger
■ Primary Limit Switch	■ Door Switch
■ Auxiliary Limit Switch	■ Coil Front Cover
■ Pressure Switch	■ Integrated Control Module
■ Induced Draft Blower	■ Transformer

TROUBLESHOOTING

Electrostatic Discharge (ESD) Precautions

NOTE: Discharge static electricity accumulated in the body before touching the unit. An electrostatic discharge can adversely affect electrical components.

Use the following steps during furnace installations and servicing to protect the integrated control module from damage. By putting the furnace, the control and the person at the same electrostatic potential, these steps will help avoid exposing the integrated control module to electrostatic discharge. This procedure is applicable to both installed and uninstalled (ungrounded) furnaces.

1. Disconnect all power to the furnace.
NOTE: Do not touch the integrated control module or any wire connected to the control prior to discharging your body's electrostatic charge to ground.
2. Firmly touch a clean, unpainted, metal surface of the furnace away from the control. Any tools held in a person's hand during grounding will be discharged also.
3. Service the integrated control module or connecting wiring after following the discharge process in Step 2.
NOTE: Do not recharge your body with static electricity by moving or shuffling your feet or touching ungrounded objects. If you touch an ungrounded object, repeat Step 2 before touching the control or wires.
4. Follow steps 1 through 3 before removing a new control from its container or installing the control on a furnace. Return any old or new controls to their containers before touching any ungrounded object.

Fault Recall

The ignition control is equipped with a momentary pushbutton switch that can be used to display the last 6 faults on the dual 7-segment LED display. The control must be in Standby Mode (no thermostat inputs) to use the feature. Depress the switch for approximately 2 seconds. Release the switch when the LED display is turned off. The last 6 faults will be displayed most recent to least recent on the dual 7-segment LED display.

NOTE: Consecutively repeated faults are stored a maximum of 3 times. For example, a clogged return air filter causes the furnace limit to trip repeatedly. The control will only store this fault the first 3 consecutive times the fault occurs.

Resetting from Lockout

Furnace lockout results when a furnace is unable to achieve ignition after 3 attempts during a single call for heat. It is characterized by a nonfunctioning furnace and a "E0" code displayed on the dual 7-segment display. If the furnace is in "lockout," it will (or can be) reset in any of the following ways.

1. Automatic reset. The integrated control module will automatically reset itself and attempt to resume normal operations following a 1-hour lockout period.
2. Manual power interruption. Interrupt 115-volt power to the furnace.
3. Manual thermostat cycle. Lower the thermostat so that there is no longer a call for heat for 1 to 20 seconds, and then reset to previous setting.

NOTE: If the condition which originally caused the lockout still exists, the control will return to lockout. Refer to the "Diagnostic Chart."

Status Codes

	Internal control fault/no power
O n	Normal operation
E 0	Lockout due to excessive retries
E 1	Low-stage pressure switch stuck closed at start of heating cycle
E 2	Low-stage pressure switch stuck open
E 3	Open high-limit switch
E 4	Flame detected when no flame should be present
E 5	Open fuse
E 6	Low flame signal
E 7	Igniter fault or improper grounding
E 8	High-stage pressure switch stuck closed at start of heating cycle
E 9	High-stage pressure switch stuck open
E A	Reversed 115 VAC polarity
d 0	Data not yet on network
d 4	Invalid memory card data

b 0	Blower motor not running
b 1	Blower communication error
b 2	Blower HP mismatch
b 3	Blower motor operating in power, temperature or speed limit
b 4	Blower motor current trip or lost rotor
b 5	Blower motor locked rotor
b 6	Over/under voltage trip or over temperature trip
b 7	Incomplete parameters sent to motor
b 9	Low indoor airflow
C 1	Low-stage cooling
C 2	High-stage cooling
L O	Low-stage heat
H I	High-stage heat
F	Continuous fan
1 2	CFM/100; Alternates with C1, C2, LO, HI, F

Diagnostic Chart



WARNING

HIGH VOLTAGE!

To avoid personal injury or death due to electrical shock, disconnect electrical power before performing any service or maintenance.



The dual 7-segment LED display will display an error code that may contain a letter and number. The error code may be used to assist in troubleshooting the unit.

Symptoms of Abnormal Operation	Diagnostic/Status LED Code	Fault Description	Possible Causes	Corrective Actions	Notes and Cautions
<ul style="list-style-type: none"> ■ Furnace fails to operate. ■ Integrated control module diagnostic LED display provides no signal. 	None	<ul style="list-style-type: none"> ■ No 115-volt power to furnace, or no 24-volt power to integrated control module. ■ Blown fuse or circuit breaker. ■ Internal fault in Integrated control module. 	<ul style="list-style-type: none"> ■ Manual disconnect switch Off, door switch open or 24-volt wire improperly connected or loose. ■ Blown fuse or circuit breaker. ■ Integrated control module has an internal fault. 	<ul style="list-style-type: none"> ■ Assure 115-volt power to the furnace, and 24-volt power to integrated control module. ■ Check integrated control module fuse. Replace with 3A automotive fuse, if necessary. ■ Check for possible shorts in 115-volt and 24-volt circuits. Repair as necessary. ■ Replace bad integrated control module. 	<ul style="list-style-type: none"> ■ Turn off power prior to repair. ■ Replace integrated control module fuse with 3A automotive fuse. ■ Read precautions in "Electrostatic Discharge" section of manual. ■ Replace integrated control module with current replacement parts.
<ul style="list-style-type: none"> ■ LED display indicates "On." 	On	<ul style="list-style-type: none"> ■ Normal operation 	<ul style="list-style-type: none"> ■ Normal operation 	<ul style="list-style-type: none"> ■ None 	<ul style="list-style-type: none"> ■ Normal operation
<ul style="list-style-type: none"> ■ Furnace fails to operate. ■ Integrated control module LED display provides "E0" error code. 	E0	<ul style="list-style-type: none"> ■ Furnace lockout due to an excessive number of ignition "retries" (3 total). 	<ul style="list-style-type: none"> ■ Failure to establish flame. Cause may be no gas to burners, front cover pressure switch stuck open, bad igniter or igniter alignment, improper orifices or coated/oxidized or improperly connected flame sensor. ■ Loss of flame after establishment. Cause may be interrupted gas supply, lazy burner flames (improper gas pressure or restriction in flue and/or combustion air piping), front cover pressure switch opening, or improper induced draft blower performance. 	<ul style="list-style-type: none"> ■ Locate and correct gas interruption. ■ Check front cover pressure switch operation (hose, wiring, contact operation). Correct if necessary. ■ Replace or realign igniter. Igniter is fragile, handle gently. ■ Check flame sense signal. Sand sensor if coated and/or oxidized. ■ Check flue piping for blockage, proper length, elbows and termination. ■ Verify proper induced draft blower performance. 	<ul style="list-style-type: none"> ■ Turn off power prior to repair. ■ Igniter is fragile, handle with care. ■ Sand flame sensor with emery cloth. ■ See "Vent/Flue Pipe" section for piping details.

Symptoms of Abnormal Operation	Diagnostic/ Status LED Code	Fault Description	Possible Causes	Corrective Actions	Notes and Cautions
<ul style="list-style-type: none"> ■ Furnace fails to operate. ■ Integrated control module LED display provides “E1” error code. 	E1	<ul style="list-style-type: none"> ■ Low-stage pressure switch circuit is closed at start of heating cycle. 	<ul style="list-style-type: none"> ■ Low-stage pressure switch contacts sticking. ■ Shorts in pressure switch circuit wiring. ■ Board timing with PCBKF101 control board will detect a closed pressure switch after a failed ignition attempt and before the next attempt. May display a misleading E1 code. 	<ul style="list-style-type: none"> ■ Replace low-stage pressure switch. ■ Repair short in wiring. ■ Disregard E1 code shown between ignition attempts if furnace is equipped with PCBKF101 control board. Look for cause of no ignition— gas supply, gas control valve switch off, improper gas manifold pressure or improper L.P. conversion. 	<ul style="list-style-type: none"> ■ Turn off power prior to repair. ■ Replace pressure switch with correct replacement part. ■ The board checks for an open pressure switch when a call for heat is received. It will only power the inducer and proceed with the call for heat if the pressure switch is open.
<ul style="list-style-type: none"> ■ Induced draft blower runs continuously with no further furnace operation. ■ Integrated control module LED display provides “E2” error code. 	E2	<ul style="list-style-type: none"> ■ Low-stage pressure switch circuit is not closed. 	<ul style="list-style-type: none"> ■ Pressure switch hose blocked, pinched or connected improperly. ■ Blocked flue and/or inlet air pipe, blocked drain system or weak induced draft blower. ■ Incorrect pressure switch setpoint or malfunctioning switch contacts. ■ Loose or improperly connected wiring. 	<ul style="list-style-type: none"> ■ Inspect pressure switch hose. Repair/replace, if necessary. ■ Inspect flue and/or inlet air piping for blockage, proper length, elbows and termination. ■ Check drain system. Correct as necessary. ■ Check induced draft blower performance. Correct as necessary. ■ Correct pressure switch setpoint or contact motion. ■ Tighten or correct wiring connection. 	<ul style="list-style-type: none"> ■ Turn off power prior to repair. ■ Replace pressure switch with correct replacement part. ■ Replace induced draft blower with correct replacement part.
<ul style="list-style-type: none"> ■ Circulator blower runs continuously. No furnace operation. ■ Integrated control module LED display provides “E3” error code. 	E3	<ul style="list-style-type: none"> ■ Primary limit or auxiliary limit circuit is open. ■ Rollout limit circuit is open. 	<ul style="list-style-type: none"> ■ Insufficient conditioned air over the heat exchanger. Blocked filters, restrictive ductwork, improper circulator blower speed, or failed circulator blower. ■ Flame rollout. ■ Misaligned burners, blocked flue and/or air inlet pipe or failed induced draft blower. ■ Loose or improperly connected wiring. 	<ul style="list-style-type: none"> ■ Check filters and ductwork for blockage. Clean filters or remove obstruction. ■ Check circulator blower speed and performance. Correct speed or replace blower if necessary. ■ Check burners for proper alignment. ■ Check flue and air inlet piping for blockage, proper length, elbows and termination. Correct as necessary. ■ Check induced draft blower for proper performance. Replace, if necessary. ■ Tighten or correct wiring connection. 	<ul style="list-style-type: none"> ■ Turn off power prior to repair. ■ See Specification Sheet applicable to your model for allowable rise range and proper circulator speed. ■ See “Vent/Flue Pipe” section for piping details.

Symptoms of Abnormal Operation	Diagnostic/Status LED Code	Fault Description	Possible Causes	Corrective Actions	Notes and Cautions
<ul style="list-style-type: none"> ■ Induced draft blower and circulator blower runs continuously. No furnace operation. ■ Integrated control module LED display provides "E4" error code. 	E4	<ul style="list-style-type: none"> ■ Flame sensed with no call for heat. 	<ul style="list-style-type: none"> ■ Short to ground in flame sense circuit. ■ Lingering burner flame. ■ Slow closing gas control valve. 	<ul style="list-style-type: none"> ■ Correct short at flame sensor or in flame sensor wiring. ■ Check for lingering flame. ■ Verify proper operation of gas control valve. 	<ul style="list-style-type: none"> ■ Turn off power prior to repair.
<ul style="list-style-type: none"> ■ No furnace operation. ■ Integrated control module LED display provides "E5" error code. 	E5	<ul style="list-style-type: none"> ■ Open fuse. 	<ul style="list-style-type: none"> ■ Short in low voltage wiring. 	<ul style="list-style-type: none"> ■ Locate and correct short in low voltage wiring. 	<ul style="list-style-type: none"> ■ Turn off power prior to repair. ■ Replace fuse with 3A automotive fuse.
<ul style="list-style-type: none"> ■ Furnace not operating. ■ Integrated control module LED display provides "E6" error code. 	E6	<ul style="list-style-type: none"> ■ Flame sense microamp signal is low. 	<ul style="list-style-type: none"> ■ Flame sensor is coated/oxidized. ■ Flame sensor incorrectly positioned in burner flame. ■ Lazy burner flame due to improper gas pressure or combustion air. 	<ul style="list-style-type: none"> ■ Sand flame sensor if coated/oxidized. ■ Inspect for proper sensor alignment. ■ Check inlet air piping for blockage, proper length, elbows and termination. ■ Compare current gas pressure to rating plate info. Adjust as needed. 	<ul style="list-style-type: none"> ■ Turn off power prior to repair. ■ Sand flame sensor with emery cloth. ■ See "Vent/Flue Pipe" section for piping details. ■ See rating plate for proper gas pressure.
<ul style="list-style-type: none"> ■ Furnace operating on low stage gas with high stage induced draft blower. ■ High stage circulator blower (temperature, of conditioned air, lower than typical). ■ Integrated control module LED display provides "E7" error code. 	E7	<ul style="list-style-type: none"> ■ Problem with igniter circuit. 	<ul style="list-style-type: none"> ■ Improperly connected igniter. ■ Shorted igniter. ■ Poor unit ground. ■ Igniter relay fault on integrated control module. 	<ul style="list-style-type: none"> ■ Check and correct wiring from integrated control module to igniter. ■ Replace shorted igniter. ■ Check and correct furnace ground wiring. ■ Check igniter output from control. Replace, if necessary. 	<ul style="list-style-type: none"> ■ Turn off power prior to repair. ■ Replace igniter with correct replacement part. ■ Replace control with correct replacement part.
<ul style="list-style-type: none"> ■ Furnace fails to operate on high stage. Furnace operates normally on low stage. ■ Integrated control module LED display provides "E8" error code. 	E8	<ul style="list-style-type: none"> ■ High-stage pressure switch circuit is closed at start of heating cycle. ■ Induced draft blower is operating. ■ Furnace is operating on low stage only. 	<ul style="list-style-type: none"> ■ High-stage pressure switch contacts sticking. ■ Shorts in pressure switch circuit wiring. 	<ul style="list-style-type: none"> ■ Replace high-stage pressure switch. ■ Repair short in wiring. 	<ul style="list-style-type: none"> ■ Turn off power prior to repair. ■ Replace pressure switch with correct replacement part.

Symptoms of Abnormal Operation	Diagnostic/Status LED Code	Fault Description	Possible Causes	Corrective Actions	Notes and Cautions
<ul style="list-style-type: none"> ■ Furnace fails to operate on high stage. Furnace operates normally on low stage. ■ Integrated control module LED display provides “E9” error code. 	E9	<ul style="list-style-type: none"> ■ High-stage pressure switch circuit is not closed. ■ Induced draft blower is operating. ■ Furnace is operating on low stage only. 	<ul style="list-style-type: none"> ■ Pressure switch hose blocked, pinched or connected improperly. ■ Blocked flue and/or inlet air pipe, blocked drain system or weak induced draft blower. ■ Incorrect pressure switch setpoint or malfunctioning switch contacts. ■ Loose or improperly connected wiring. 	<ul style="list-style-type: none"> ■ Inspect pressure switch hose. Repair, if necessary. ■ Inspect flue and/or inlet air piping for blockage, proper length, elbows and termination. ■ Check drain system. Correct as necessary. ■ Check induced draft blower performance. Correct as necessary. ■ Correct pressure switch setpoint or contact motion. ■ Tighten or correct wiring connection. 	<ul style="list-style-type: none"> ■ Turn off power prior to repair. ■ Replace pressure switch with correct replacement part. ■ Replace induced draft blower with correct replacement part.
<ul style="list-style-type: none"> ■ Furnace fails to operate. ■ Integrated control module LED display provides “EA” error code. 	EA	<ul style="list-style-type: none"> ■ Polarity of 115-volt AC is reversed. 	<ul style="list-style-type: none"> ■ Polarity of 115-volt AC power to furnace or integrated module is reversed. ■ Poor furnace ground. 	<ul style="list-style-type: none"> ■ Review wiring diagram to correct polarity. ■ Verify proper ground. Correct if necessary. ■ Check and correct wiring. 	<ul style="list-style-type: none"> ■ Turn off power prior to repair.
<ul style="list-style-type: none"> ■ Furnace fails to operate. ■ Integrated control module LED display provides “d0” error code. 	d0	<ul style="list-style-type: none"> ■ Data not yet on network. 	<ul style="list-style-type: none"> ■ Furnace does not contain any shared data. 	<ul style="list-style-type: none"> ■ Populate shared data set using memory card. 	<ul style="list-style-type: none"> ■ Turn off power prior to repair. ■ Use memory card for the specific model. ■ Insert memory card before turning on power. Memory card may be removed after data is loaded. ■ Turn off power before removing memory card. ■ Error code will be cleared once data is loaded.
<ul style="list-style-type: none"> ■ Operation different than expected or no operation. ■ Integrated control module LED display provides “d4” error code. 	d4	<ul style="list-style-type: none"> ■ Invalid memory card data. 	<ul style="list-style-type: none"> ■ Shared data set on memory card has been rejected by integrated control module. 	<ul style="list-style-type: none"> ■ Verify shared data set is correct for the specific model. ■ Repopulate data using correct memory card, if required. 	<ul style="list-style-type: none"> ■ Turn off power prior to repair. ■ Use memory card for the specific model. ■ Insert memory card before turning on power. Memory card may be removed after data is loaded. ■ Turn off power before removing memory card. ■ Error code will be cleared once data is loaded.

Symptoms of Abnormal Operation	Diagnostic/ Status LED Code	Fault Description	Possible Causes	Corrective Actions	Notes and Cautions
<ul style="list-style-type: none"> ■ Furnace fails to operate. ■ Integrated control module LED display provides “b0” error code. 	b0	<ul style="list-style-type: none"> ■ Circulator blower motor is not running when it should be running. 	<ul style="list-style-type: none"> ■ Loose wiring connection at circulator motor power leads or circulator motor power leads disconnected. ■ Open circuit in inductor or loose wiring connection at inductor (¾ Hp and 1 Hp models only). ■ Failed circulator blower motor. 	<ul style="list-style-type: none"> ■ Tighten or correct wiring connection. ■ Verify continuous circuit through inductor. Replace if open or short circuit. ■ Check circulator blower motor. Replace if necessary. 	<ul style="list-style-type: none"> ■ Turn off power prior to repair. ■ Replace inductor with correct replacement part. ■ Replace circulator motor with correct replacement part.
<ul style="list-style-type: none"> ■ Furnace fails to operate. ■ Integrated control module LED display provides “b1” error code. 	b1	<ul style="list-style-type: none"> ■ Integrated control module has lost communications with circulator blower motor. 	<ul style="list-style-type: none"> ■ Loose wiring connection at circulator motor control leads. ■ Failed circulator blower motor. ■ Failed integrated control module. 	<ul style="list-style-type: none"> ■ Tighten or correct wiring connection. ■ Check circulator blower motor. Replace if necessary. ■ Check integrated control module. Replace if necessary. 	<ul style="list-style-type: none"> ■ Turn off power prior to repair. ■ Replace circulator motor with correct replacement part. ■ Replace integrated control module with correct replacement part.
<ul style="list-style-type: none"> ■ Furnace fails to operate. ■ Integrated control module LED display provides “b2” error code. 	b2	<ul style="list-style-type: none"> ■ Circulator blower motor horse power in shared data set does not match circulator blower motor horse power. 	<ul style="list-style-type: none"> ■ Incorrect circulator blower motor in furnace. ■ Incorrect shared data set in integrated control module. 	<ul style="list-style-type: none"> ■ Verify circulator blower motor horse power is the same specified for the specific furnace model. Replace if necessary. ■ Verify shared data set is correct for the specific model. Repopulate data using correct memory card, if required. 	<ul style="list-style-type: none"> ■ Turn off power prior to repair. ■ Replace motor with correct replacement part. ■ Use memory card for the specific model. ■ Insert memory card before turning on power. Memory card may be removed after data is loaded. ■ Turn off power before removing memory card. ■ Error code will be cleared once shared data and motor horse power match.
<ul style="list-style-type: none"> ■ Furnace operates at reduced performance. ■ Airflow delivered is less than expected. ■ Integrated control module LED display provides “b3” error code. 	b3	<ul style="list-style-type: none"> ■ Circulator blower motor is operating in a power, temperature or speed limiting condition. 	<ul style="list-style-type: none"> ■ Blocked filters. ■ Restrictive ductwork. ■ Undersized ductwork. ■ High ambient temperatures. 	<ul style="list-style-type: none"> ■ Check filters for blockage. Clean filters or remove obstruction. ■ Check ductwork for blockage. Remove obstruction. Verify all registers are fully open. ■ Verify ductwork is appropriately sized for system. Resize/replace ductwork if necessary. ■ See “Product Description” and “Location Requirements and Considerations” for furnace installation requirements. 	<ul style="list-style-type: none"> ■ Turn off power prior to repair.

Symptoms of Abnormal Operation	Diagnostic/ Status LED Code	Fault Description	Possible Causes	Corrective Actions	Notes and Cautions
<ul style="list-style-type: none"> ■ Furnace fails to operate. ■ Integrated control module LED display provides “b4” error code. 	b4	<ul style="list-style-type: none"> ■ Circulator blower motor senses a loss of rotor control. ■ Circulator blower motor senses high current. 	<ul style="list-style-type: none"> ■ Abnormal motor loading, sudden change in speed or torque, sudden blockage of furnace air inlet or outlet. ■ High loading conditions, blocked filters, very restrictive ductwork, blockage of furnace air inlet or outlet. 	<ul style="list-style-type: none"> ■ Check filters, filter grills/registers, duct system and furnace air inlet/outlet for blockages. 	<ul style="list-style-type: none"> ■ Turn off power prior to repair.
<ul style="list-style-type: none"> ■ Furnace fails to operate. ■ Integrated control module LED display provides “b5” error code. 	b5	<ul style="list-style-type: none"> ■ Circulator blower motor fails to start 10 consecutive times. 	<ul style="list-style-type: none"> ■ Obstruction in circulator blower housing. ■ Seized circulator blower motor bearings. ■ Failed circulator blower motor. 	<ul style="list-style-type: none"> ■ Check circulator blower for obstructions. Remove and repair/replace wheel/motor, if necessary. ■ Check circulator blower motor shaft rotation and motor. Replace motor if necessary. 	<ul style="list-style-type: none"> ■ Turn off power prior to repair. ■ Replace motor with correct replacement part. ■ Replace wheel with correct replacement part.
<ul style="list-style-type: none"> ■ Furnace fails to operate. ■ Integrated control module LED display provides “b6” error code. 	b6	<ul style="list-style-type: none"> ■ Circulator blower motor shuts down for over or under voltage condition. ■ Circulator blower motor shuts down due to over temperature condition on power module. 	<ul style="list-style-type: none"> ■ High AC line voltage to furnace. ■ Low AC line voltage to furnace. ■ High ambient temperatures. 	<ul style="list-style-type: none"> ■ Check power to furnace. Verify line voltage to furnace is within the range specified on the furnace rating plate. ■ See “Product Description” and “Location Requirements and Considerations” for furnace installation requirements. 	<ul style="list-style-type: none"> ■ Turn off power prior to repair.
<ul style="list-style-type: none"> ■ Furnace fails to operate. ■ Integrated control module LED display provides “b7” error code. 	b7	<ul style="list-style-type: none"> ■ Circulator blower motor does not have enough information to operate properly. ■ Motor fails to start 40 consecutive times. 	<ul style="list-style-type: none"> ■ Error with integrated control module. ■ Motor has a locked rotor condition. 	<ul style="list-style-type: none"> ■ Check integrated control module. Verify control is populated with correct shared data set. See data errors above for details. ■ Check for locked rotor condition (see error code above for details). 	<ul style="list-style-type: none"> ■ Turn off power prior to repair. ■ Replace with correct replacement part(s). ■ Use memory card for the specific model.
<ul style="list-style-type: none"> ■ Furnace operates at reduced performance or operates on low stage when high stage is expected. ■ Integrated control module LED display provides “b9” error code. 	b9	<ul style="list-style-type: none"> ■ Airflow is lower than demanded. 	<ul style="list-style-type: none"> ■ Blocked filters. ■ Restrictive ductwork. ■ Undersized ductwork. 	<ul style="list-style-type: none"> ■ Check filters for blockage. Clean filters or remove obstruction. ■ Check ductwork for blockage. Remove obstruction. Verify all registers are fully open. ■ Verify ductwork is appropriately sized for system. Resize/replace ductwork if necessary. 	<ul style="list-style-type: none"> ■ Turn off power prior to repair.

DIP Switch Chart

WARNING

HIGH VOLTAGE!

To avoid personal injury or death due to electrical shock, disconnect electrical power before performing any service or maintenance.



Switch			DIP Switch Number									
			1	2	3	4	5	6	7	8	9	10
Bank	Purpose	Function										
S1	Heat Off Delay	90 Seconds	Off	Off	---	---	---	---	---	---	---	---
		120 Seconds	On	Off	---	---	---	---	---	---	---	---
		150 Seconds*	Off	On	---	---	---	---	---	---	---	---
		180 Seconds	On	On	---	---	---	---	---	---	---	---
	Thermostat Setup	1-Stage T-Stat	---	---	Off	---	---	---	---	---	---	---
		2-Stage T-Stat	---	---	On	---	---	---	---	---	---	---
		5-Min Delay	---	---	---	Off	---	---	---	---	---	---
		Auto Delay	---	---	---	On	---	---	---	---	---	---
S2	Bus BIAS	BIAS	On*	On*	---	---	---	---	---	---	---	
	TERM	Bus Termination	---	---	On*	---	---	---	---	---	---	
S3	Cooling Speed Tap	A	Off	Off	---	---	---	---	---	---	---	
		B	On	Off	---	---	---	---	---	---	---	
		C	Off	On	---	---	---	---	---	---	---	
		D*	On	On	---	---	---	---	---	---	---	
	Adjust Taps	Normal*	---	---	Off	Off	---	---	---	---	---	
		10%	---	---	On	Off	---	---	---	---	---	
		-10%	---	---	Off	On	---	---	---	---	---	
		Normal	---	---	On	On	---	---	---	---	---	
S4	Ramping Profiles	A*	---	---	---	---	Off	Off	---	---	---	
		B	---	---	---	---	On	Off	---	---	---	
		C	---	---	---	---	Off	On	---	---	---	
		D	---	---	---	---	On	On	---	---	---	
	Heating Speed Tap	A	---	---	---	---	---	---	Off	Off	---	
		B*	---	---	---	---	---	---	On	Off	---	
		C	---	---	---	---	---	---	Off	On	---	
		D	---	---	---	---	---	---	On	On	---	
S5	DEHUM	Disabled*	---	---	---	---	---	---	---	---	Off	Unused
		Enabled	---	---	---	---	---	---	---	---	On	Unused

*Indicates factory setting

--- Not applicable

WIRING DIAGRAM

WARNING

HIGH VOLTAGE!

Disconnect ALL power before servicing.
Multiple power sources may be present.
Failure to do so may cause property damage, personal injury or death.

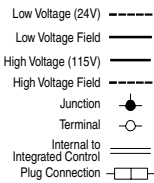
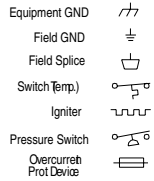

Color	Symbol
Gray:	GY
White:	W
Black:	BK
Red:	R
Blue:	BU
Orange:	OR
Yellow:	Y
Green:	G
Pink:	PK
Azure:	A
Violet:	V
Brown:	BR

Wiring is subject to change.
Always refer to the wiring
diagram on the unit for the
most up-to-date wiring.

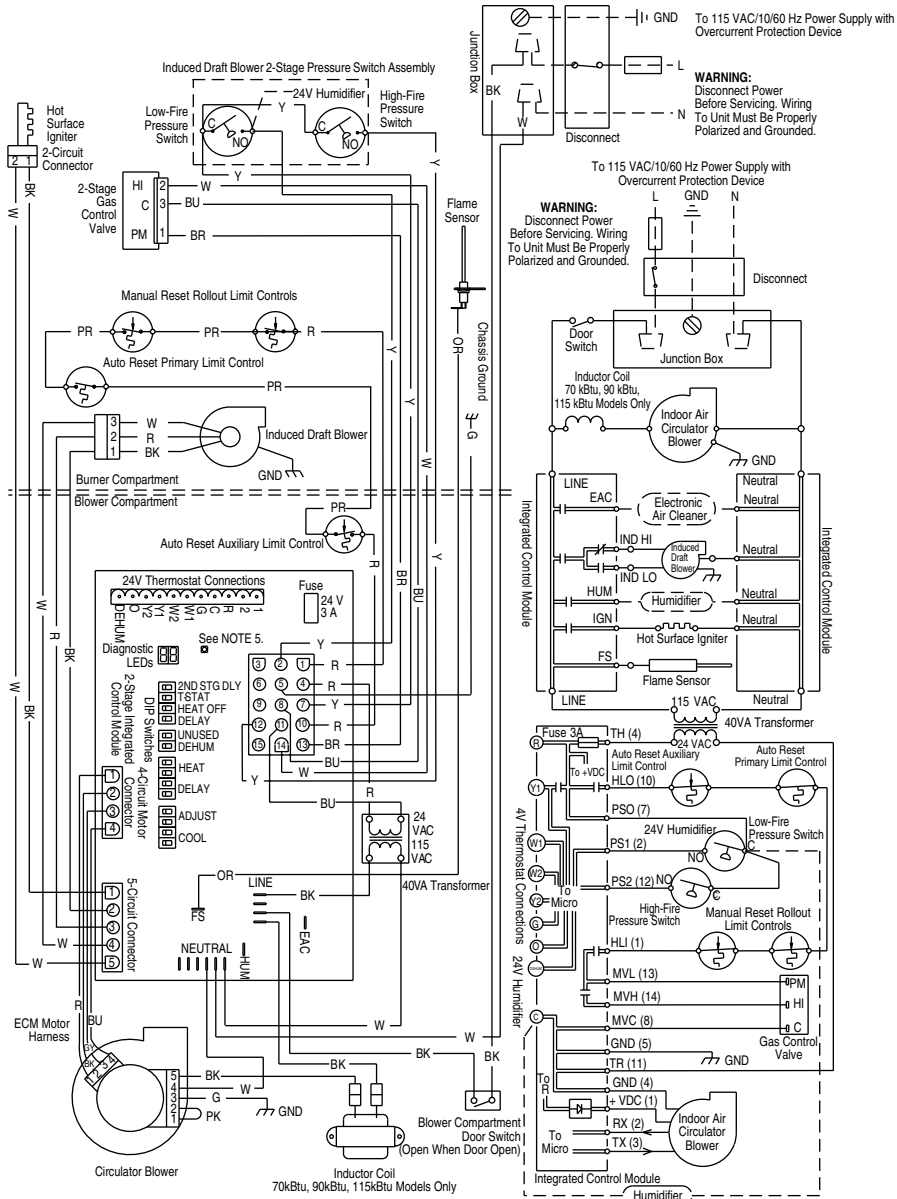

Check codes for proper wiring and circuit protection before installation.

NOTES:

1. Set heat anticipator on room thermostat at 0.7 amps.
2. Manufacturer's specified replacement parts must be used when servicing.
3. If any of the original wire as supplied with the furnace must be replaced, it must be replaced with wiring material having a temperature rating of at least 105°C. Use copper conductors only.
4. Furnace must be permanently grounded and conform to NEC and local codes.
5. To recall the last 6 faults, most recent to least recent, depress switch for more than 2 seconds in standby (no thermostat inputs).

ASSISTANCE OR SERVICE

If you need further assistance, you can write to the below address with any questions or concerns:

Tradewinds Distributing Company, LLC
14610 Breakers Drive
Jacksonville, FL 32258

Please include a daytime phone number in your correspondence.

Or call toll free: 1-866-944-7575.